

OLD TOWN NEIGHBORHOODS - DESIGN GUIDELINES

Final: February 21, 2017



Old Town Neighborhoods Design Guidelines

Adopted February 21, 2017

Planning Services
281 North College Avenue
Fort Collins, CO 80524

(970) 221-6750
www.fcgov.com/planning

For additional copies, please download from our
website, or contact us using the information above

TABLE OF CONTENTS

- Introduction 3
- Purpose 3
- How This Document Is Used 6
- Design Guidelines Format..... 6
- Design Guideline Steps..... 7

- Neighborhood Character Areas 11
- Community Identified Features 11
- Historic Architectural Styles..... 12
- Character Areas 23

- Design Guidelines for the Treatment of Historic Resources 41
- General Preservation Principles 42
- Character-Defining Features 44
- Materials and Finishes 46
- Windows..... 48
- Doors and Entries..... 52
- Porches, Decks and Balconies 53
- Historic Roofs..... 56
- Exposed Historic Foundations..... 57
- Paint 58
- Color 58
- Accessory Buildings and Carriage Houses..... 59
- Existing Additions 59
- Enhancing Energy Performance..... 62
- Maintaining Energy Efficiency 62
- Using Energy Generating Technologies 63

- Building Design: Guidelines for New Construction..... 67
- Designing in Context 67
- Building Design 68
- Building Mass and Scale 71
- Building Articulation 73
- Porches, Entry Features, Balconies and Decks 75

Doors and Windows	78
Materials	80
Eaves	82
Additions.....	84
Connectors	88
Accessory Buildings and Carriage Houses.....	89
Green Building and The Climate Action Plan.....	91

Site Design: Guidelines for New Construction 95

Building Location	95
Parking.....	96
Vehicular Access	96
Landscape and Site Features.....	97
Urban Gardens	99
Service Areas.....	100

Appendix..... 101

Character Area Summary Charts.....	103
Resource List	107
Glossary	108

ACKNOWLEDGEMENTS

Fort Collins City Council

Wade Troxell, Mayor
Gerry Horak, Mayor Pro Tem, District 6
Bob Overbeck, District 1
Ray Martinez, District 2
Gino Campana, District 3
Kristin Stephens, District 4
Ross Cunniff, District 5

City Leadership

Darin Atteberry, City Manager
Jeff Mihelich, Deputy City Manager
Laurie Kadrich, Planning, Development, and Transportation (PDT) Director
Tom Leeson, Community Development and Neighborhood Services (CDNS) Director
Cameron Gloss, Planning Manager

Project Management Team

Pete Wray, Senior City Planner – Project Lead
Meaghan Overton, City Planner – Project Manager
Cassandra Bumgarner, Historic Preservation Planner
Maren Bzdek, Historic Preservation Planner
Clay Frickey, City Planner
Karen McWilliams, Historic Preservation Manager
Ryan Mounce, City Planner

Boards and Commissions

Planning and Zoning Board
Landmark Preservation Commission

Consultant Team

Julie Husband, Winter & Company
Christopher Ball, Winter & Company

ACKNOWLEDGEMENTS

Old Town Neighborhoods Plan Stakeholder Group

Westside

Al & Janeen Kulenski
Zach & Laura Wilson
Meg Dunn
Kevin Murray
Hugh Mackay
Roland Baschmann
Doug & Denise Newberry
William Whitley
Kelly Deligio
Michelle Haefele
Catherine Cole Janonis
Gayle Wernsman
Jack Mullen
Tami Agne
Michele Christensen
Chris Kelly

Eastside

Mike Coley
Kendra Spanjer
Tamela Wahl
Margo Carlock
Patrick Flynn
Kristina Kachur
Jodie Riesenberger
Lisa Moravan
Greg Rittner
Paulette Dolin
Seth Jansen
Lisa Kohl
Sheila Dielman



I

INTRODUCTION

Introduction



PURPOSE

The Old Town Neighborhoods are among the most cherished residential sections of Fort Collins. Extending east and west of the downtown, these neighborhoods support a high quality of life with walkable streets and buildings that convey an eclectic mix of character and scale that is unique as compared to the entire community.

Many homes in these neighborhoods date from the early years of the city and are recognized for their historic significance. Some of the east side homes are contained within the Laurel School National Register Historic District. Some individual buildings also are listed as local landmarks under the City’s preservation ordinance, and others are identified in cultural resources surveys as being eligible for listing in the National Register or as Fort Collins Landmarks.

Other residences may not be individually eligible for historic designation but contribute to the sense of continuity in scale, character, form and materials that exists in the neighborhoods. These structures, along with those of historic character define the context for building in the Old Town Neighborhoods.

In recent years, residents have voiced their goals for maintaining the traditional character of the Old Town Neighborhoods while encouraging renovation of existing buildings and accommodating compatible new construction. City Council updated the zoning code for this area in 2013, in which certain standards related to mass and scale were adopted to promote compatibility. Recent neighborhood planning efforts also have identified objectives for encouraging compatible infill. While change continues to occur, retaining the existing character and embracing sustainability remain primary goals for the neighborhoods.

This document represents an update to the original Design Guidelines developed in 1996, and is an implementation action of the 2016 Old Town Neighborhoods Plan. It provides design guidelines and identifies neighborhood character areas to consider when rehabilitating existing buildings and for new “infill” construction. This document also builds on the policies established in other planning documents. Finally, it provides more detailed guidance to help property owners find compatible solutions that respond to the existing neighborhood context.

HISTORIC REVIEW

Historic review is required for exterior changes to buildings fifty years old and older and for land surface changes, including new construction on these properties. Many proposed changes may be approved administratively by staff; otherwise the proposed work goes to the Landmark Preservation Commission (LPC) for design review.

The LPC and City staff shall take these factors into consideration when reviewing proposed work:



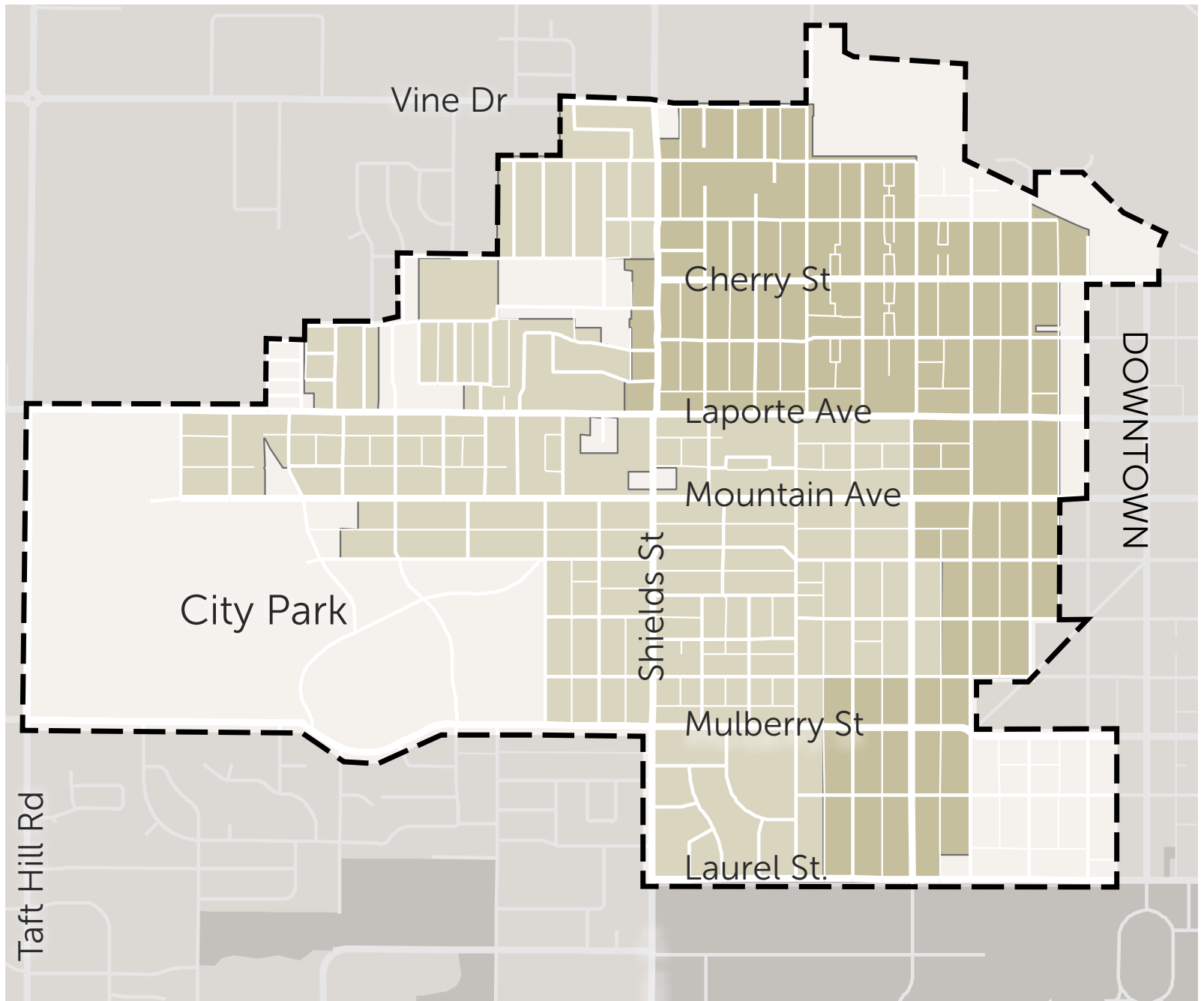

- › The significance of the property
- › The context, with respect to other historic properties
- › The location of any key, character-defining features
- › The condition of those features
- › The landmark status

In addition, there are many cases in which these guidelines state that one particular solution is preferred, such as for the replacement of a damaged or missing feature, but the text further notes that some alternatives may be considered if the preferred approach is not feasible. In determining such feasibility, the City will also consider:

- › The reasonable availability of the preferred material
- › The skill required to execute the preferred approach
- › The quality, appearance and character of alternative solutions, such as new materials



Legend

-  Neighborhood Boundary
-  Neighborhood Conservation - Low Density
-  Neighborhood Conservation - Medium Density
-  Colorado State University

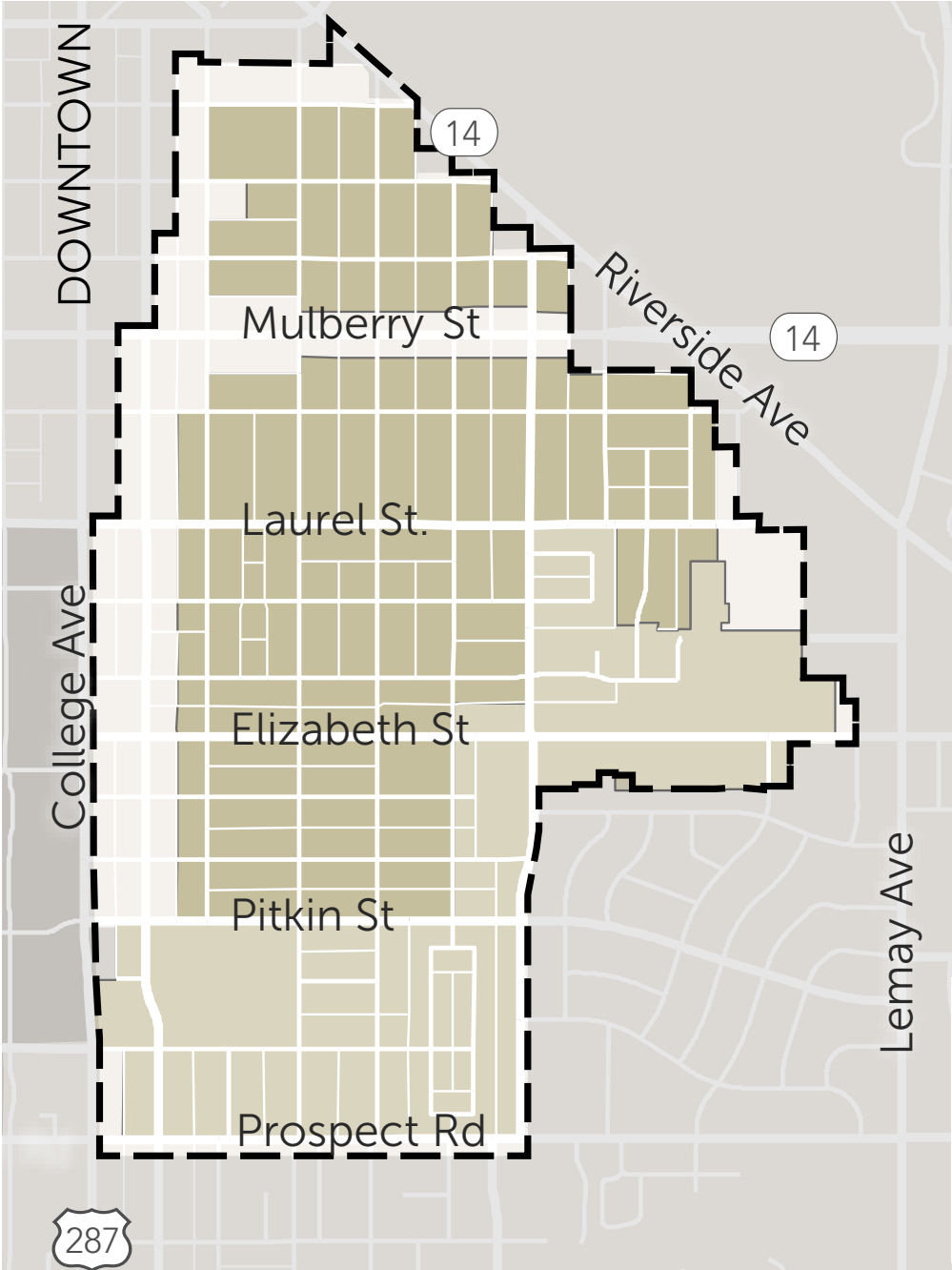

ZONING DISTRICT MAPS

These Design Guidelines apply to the Neighborhood Conservation, Low Density (NCL) and Neighborhood Conservation, Medium Density (NCM) zone districts.

- Legend
- Neighborhood Boundary
 - Neighborhood Conservation - Low Density
 - Neighborhood Conservation - Medium Density
 - Colorado State University

HOW THIS DOCUMENT IS USED

Preparing for Home Improvement

These guidelines are for voluntary and advisory use. Property owners, designers, and contractors are encouraged to draw upon the principles set forth here when planning improvements to homes in the neighborhoods. The City’s Design Assistance Program provides funding for approved professionals to apply the guidelines to achieve compatible plans for alterations and new construction.

Evaluating Real Estate

Potential home buyers and real estate agents can use these guidelines to understand the value of character-defining features in homes available for purchase and to understand the best options for repair, renovation, or additions.

Design Review Guidance

City staff and the Landmark Preservation Commission use the guidelines as a tool for understanding options that are compatible with the character of the district and the particular building type when conducting historic review. For example, the review process for proposed changes to properties located in the Laurel School Historic District, or other properties that are listed or eligible for historic designation, may benefit from the information provided in this document. Similarly, designated landmark property owners who wish to apply for the City’s zero-interest loan program or State tax

credits will also find the Design Guidelines useful for planning compatible improvements or repairs that could be eligible for these incentive programs and protect the historic character of the property.

Additional Resources

Historic Preservation Programs and Processes: <http://www.fcgov.com/historicpreservation/>

Design Assistance Program: <http://www.fcgov.com/historicpreservation/design-assistance.php>

Landmark Rehabilitation Loans: <http://www.fcgov.com/historicpreservation/landmark-rehabilitation.php>

DESIGN GUIDELINES FORMAT

This document is intended to be user-friendly. Users can navigate through the document by following “Design Review Tracks” that correspond to the type of work being proposed. Illustrations provide multiple options of compatible designs to help convey the intent of the Design Guidelines.

Neighborhood character area descriptions are also included in this document to describe more detailed characteristics of particular areas within the Old Town Neighborhoods. The character area sections illustrate how building components like roof forms, porches and side-yard setbacks can be combined to create designs that fit the context of a character area.

Permitted and Prohibited Solutions

In many cases, images and diagrams throughout this document are marked to indicate whether they represent permitted or prohibited solutions.



A check mark indicates more compatible and permitted solutions.



An “X” mark indicates less compatible solutions that are inappropriate.

Design Guidelines Organization

DESIGN GUIDELINE STEPS

When using the Design Guidelines there are two “steps” to aid in identifying which chapters apply to a specific project. (See the chart on the following page.)

Follow these steps to get started:

Step 1: What Type of Improvement?

Determine the nature of the improvements that are planned. There are three categories:

Historic Property

If improvements are planned to a historic building, determine if the project will be a rehabilitation of the structure, or an addition to the historic structure. If an addition is desired, the New Construction Guidelines will apply to the project.

New Construction

Will the planned improvements include construction of a new building or accessory building? Or will the planned improvements apply to an existing non-historic building? See the chart on the following page to identify which chapters apply to these two types of projects.

Other Improvements

Other improvements including the site work, placement of a new building on the lot, driveways, landscape, fences and other miscellaneous project improvements should follow the Character Areas Guidelines chapter and the Site Design Guidelines chapter.

Step 2: What Type of Existing Building?

Historic Property

A “historic” property is one that is more than fifty years old and that possesses sufficient integrity to convey its history, or is capable of yielding important information about a significant historic period in the city.

Note that some properties may have experienced some degree of alteration from their historic designs. These alterations may include window replacement, cornice removal, a porch enclosure or covering of a building’s historic materials. Nonetheless, these altered properties may retain sufficient building fabric to still be considered historically significant. For all historic properties, the Design Guidelines for the Treatment of Historic Resources Chapter should be considered when planning improvements.

Nonhistoric

The classification of “nonhistoric” applies to existing buildings that are less than fifty years old, or do not possess sufficient significance and/or exterior integrity necessary for historic designation. The Building Design Guidelines for New Construction Chapter applies to these properties.

Terminology Note:

Often times the term “remodel” is used in common language. In this case the term “rehabilitation” should be used when identifying the project type and applicable guidelines.

Determining a Historic Property:

The U.S. Department of the Interior, National Park Service, National Register Criteria for Evaluation defines a historic property as a property achieving significance within the past 50 years if it is of exceptional importance.

If your original property is not built within the last 50 years, staff review will be necessary to determine if the property is historic.

WHAT IS THE BEST APPROACH, AND WHAT CHAPTERS SHOULD I USE?

The document is organized into chapters that address different types of projects, including: historic building, non-historic building, new construction and other types of improvements. Use the chart below to identify which chapters apply to your type of project.

PROJECT TYPE		CHAPTER TO USE:				
		1. Introduction	2. Neighborhood Character Areas	3. Design Guidelines for the Treatment of Historic Resources	4. Building Design: Guidelines for New Construction	5. Site Design: Guidelines for New Construction
Historic Property	Rehabilitation of a Historic Property	✓	✓	✓		
	Addition to a Historic Property	✓	✓	✓	✓	
New Construction	Improve a Non-historic Property	✓	✓		✓	
	Construction of a New Building	✓	✓		✓	
Other Improvements	New Site Work	✓	✓			✓

(+) Guidelines could apply to some projects in this category.

Figure 1: Applicable Chapters Chart.

2

NEIGHBORHOOD CHARACTER AREAS

Neighborhood Character Areas



The Old Town Neighborhoods are diverse, with a range of existing architectural styles, building sizes, features, and contexts. These conditions reflect historic development patterns and influence how we perceive the compatibility of new development and alterations. Understanding neighborhood characteristics, including physical conditions and dynamic aspects such as past and future changes, is important for retaining the unique character of the neighborhoods.

This chapter identifies the Old Town Neighborhoods character areas and the variables that define them. It is organized under the following sections:

Community Identified Features: This section identifies a list of the most commonly identified qualitative and physical neighborhood features of value to residents that should be considered when rehabilitating a historic house or developing a new project. Note this list was developed by residents of the community in an earlier planning project to develop zoning updates for the neighborhoods.

Architectural Styles: This section identifies the historic architectural styles found throughout the neighborhoods. A list of the character-defining features for each style is provided. It is supplemented with annotated sketches and photographs. A key objective is to maintain the character-defining features of individual historic properties.

Character Areas: This section maps the character areas and identifies the variables for each area. In addition, photographs are provided to assist the user in understanding each of the variables that have been identified. The key objective is to retain the overall character of the area while accommodating creative, yet compatible new buildings and additions. Note: the character areas were developed by residents of the community in an earlier planning project to develop zoning updates for the neighborhoods.

COMMUNITY IDENTIFIED FEATURES

The 2012 Eastside and Westside Neighborhoods Strategy Report had an extensive community engagement process. As a part of the process, members of the community were asked to identify and describe a series of features which make the neighborhoods unique and desirable to live in.

Feedback from residents was largely consistent and included both physical and social characteristics. The most common traits they described include friendly neighbors, diversity in people and buildings, and walkability. The following sections summarize the most commonly identified qualitative and physical neighborhood features of value to residents.

Valued qualitative aspects of neighborhood character include:

- › Old charm and character of houses
- › Friendly/neighborly sense of community
- › Family/kid-friendly
- › Modest homes
- › Socioeconomic diversity
- › Evident pride of ownership
- › Diversity in ownership patterns
- › Does not have an HOA

Valued physical aspects of neighborhood character include:

- › Walkability and bikability
- › Proximity to amenities (including parks, schools, playgrounds, Old Town, trolley, CSU, etc.)
- › Historic character and homes
- › Integrity within blocks
- › Wide streets
- › Detached sidewalks
- › Variety in lot types
- › Alleys
- › Front porches
- › Views through lots
- › Not all fenced
- › Trees
- › Relative low density
- › Diversity of house style, age and scale
- › Uniqueness of character among Fort Collins neighborhoods
- › Less car-oriented design
- › Orientation towards neighbors
- › Houses designed with sustainability aspects already built into them

HISTORIC ARCHITECTURAL STYLES

This section provides a brief overview of various historic styles found in the Old Town Neighborhoods Character Areas. Use the styles section to determine an existing building's historic style and its character-defining features. Ultimately, this will aid in choosing an appropriate design solution for any proposed work. Note that styles are rarely pure in form, and a wide range exists within individual styles. In some cases, alterations may have occurred that make some of the features less characteristic of the building's styles.



FOURSQUARE (C. 1895-1915)

The Foursquare architectural style is recognized by its square plan, two-story height and simplicity. The majority of these houses were built during the first three decades of the twentieth century.

Character-defining features:

- » Square Plan
- » Full, Open One-Story Porch
- » Hipped, Shed or Gabled Roof
- » Simplified Doric or Tuscan Columns
- » Wide Eaves
- » Two or more Stories
- » Unadorned Exterior

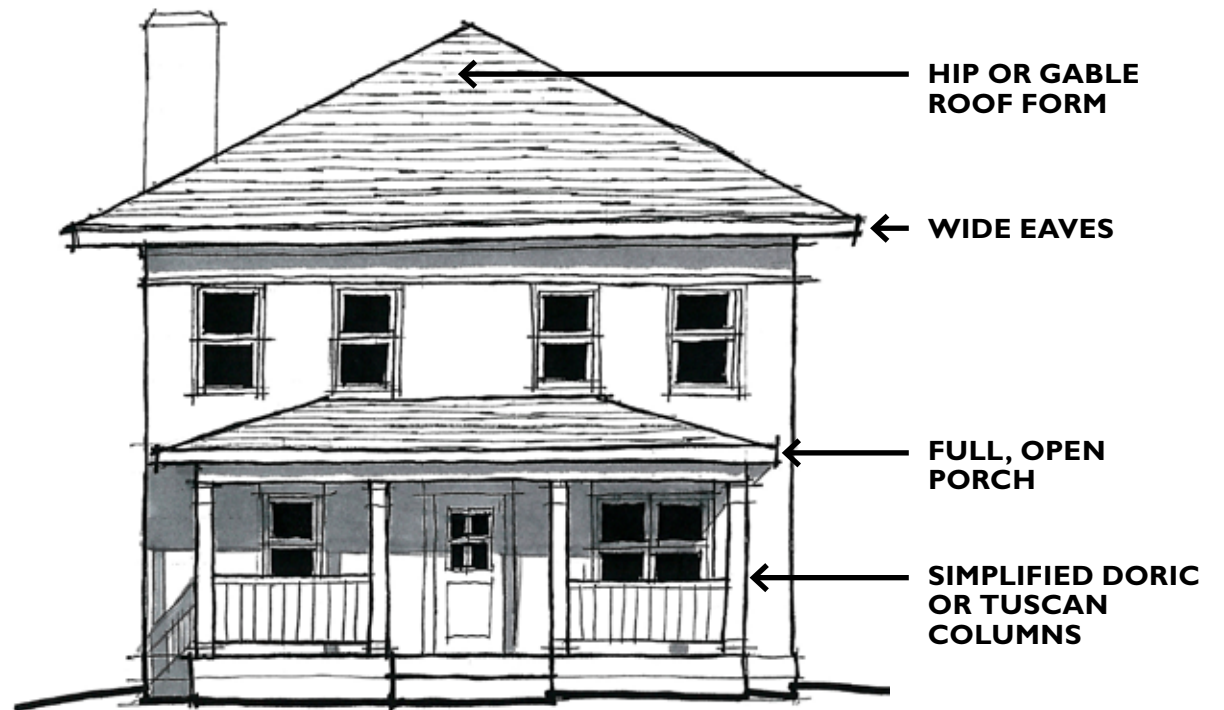

CLASSIC COTTAGE (C. 1910-1930)

The Classic Cottage features an elongated or square hipped roof with central dormer, and front porch, often full-width, with thick porch posts or simplified doric columns supporting the porch roof. Sometimes the porch is inset beneath the house roof. Architectural features of a Classic Cottage are similar to the features of a Foursquare, with the primary difference being a Classic Cottage is one-story.

Character-defining features:

- » Central Dormer
- » Hipped Roof
- » Flared Eaves at Dormer and/or Roof
- » Masonry Porch Posts or Simplified Doric Columns
- » Brick, and on some occasions Wood Frame

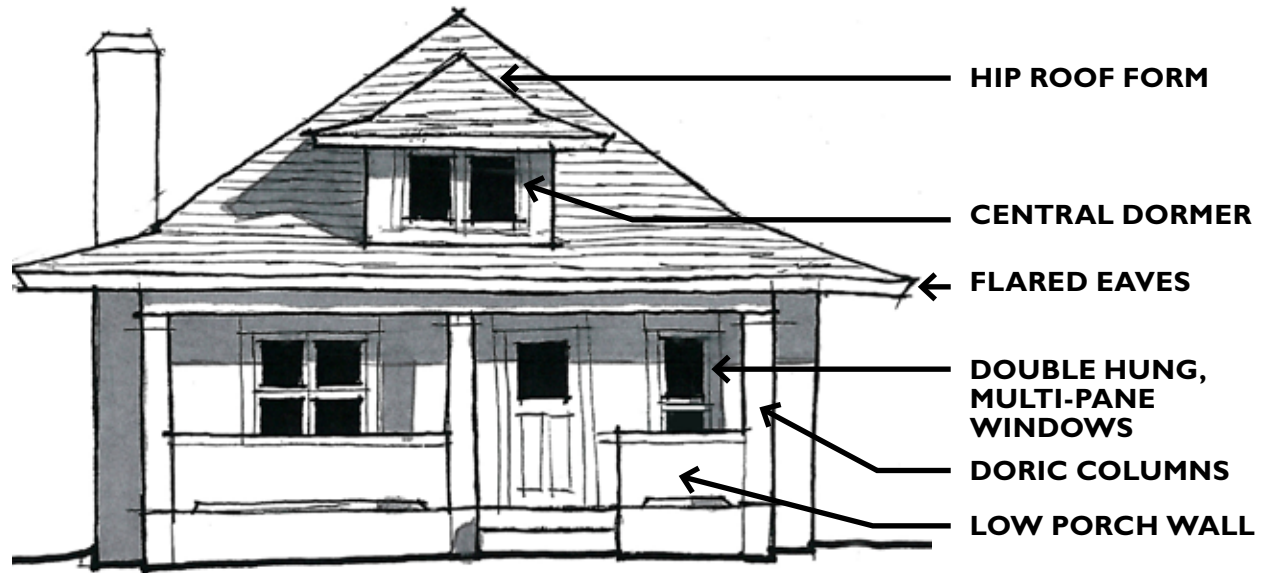

CRAFTSMAN (C. 1905-1930)

The Craftsman style structure emerged from the Arts and Crafts movement, a philosophy which stressed comfort and utility through the use of natural materials and a lack of pretension. Elements such as low-pitched, gabled roofs, wide eaves, exposed roof rafters and porches with tapered columns were common. In more elaborate designs elements such as half-timbering, knee braces at eaves, and clipped gable roof forms were present.

Character-defining features:

- » Exposed Rafter Ends
- » Hip or Gable Roof Form
- » Divided Upper Window Lights
- » Battered or Squared Porch Columns
- » Baluster or Low Porch Wall
- » Overhanging Eaves

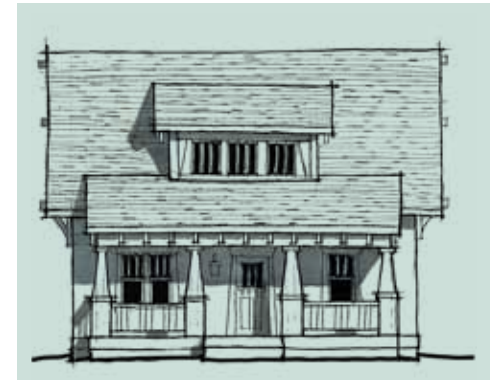
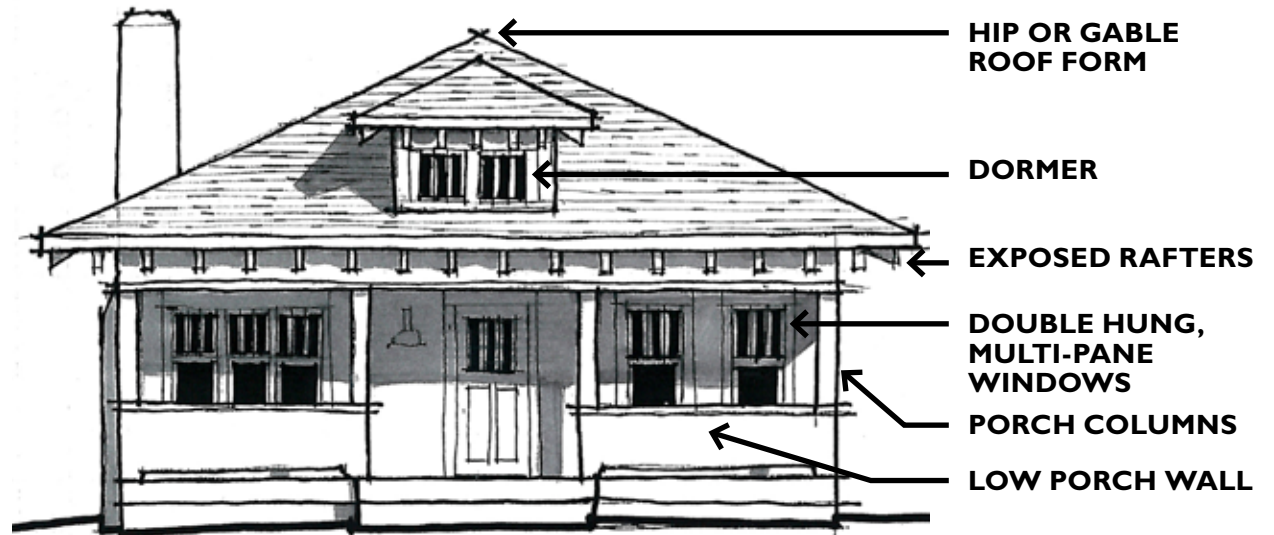

CHAPTER 2: NEIGHBORHOOD CHARACTER AREAS

QUEEN ANNE (C. 1880-1910)

Queen Anne is perhaps the most ornate style of the Victorian period evident in Colorado. The style varies from the highly decorative to a more restrained version found throughout the neighborhoods.

Character-defining features:

- » Vertical Orientation
- » Asymmetrical Massing
- » Corner Towers and Bays
- » Prominent Decorative Porches
- » Projecting Gables
- » Contrasting Materials, Particularly Brick and Wood
- » Turned Spindles
- » Bargeboard

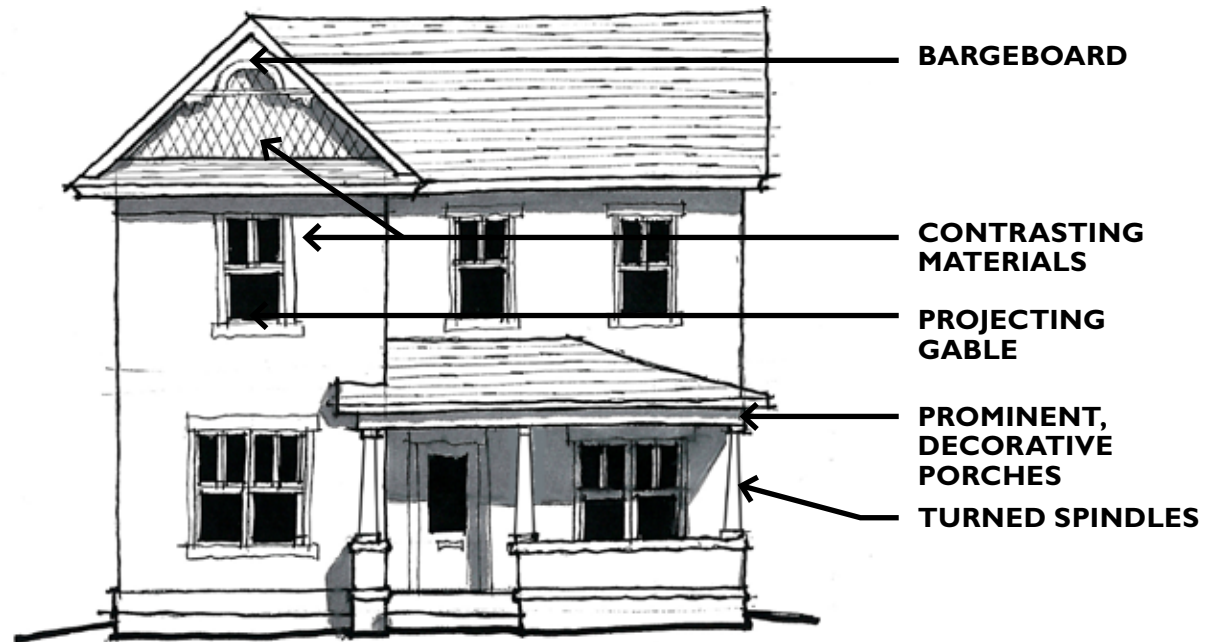

VERNACULAR (C.1885-1910)

Sometimes referred to as “other,” no style” or “folk houses,” vernacular residential types strive only to be functional. The houses are constructed of simple designs, some of which remained common for decades. Elements from other styles may appear on the vernacular but are undistinguishable due to their simplicity.

Character-defining features:

- » Gable and Hipped Roofs
- » Front Facing Open Porch
- » Simple Columns
- » Wood, Double-Hung Windows
- » Clapboard Wood Siding, or Shingles
- » Simple Detailing



CHAPTER 2: NEIGHBORHOOD CHARACTER AREAS

TUDOR REVIVAL (C. 1910-1920)

The most dominant features of the typical Revival style are the false or ornamental half-timbering, which covers the upper story, and the steeply pitched roof. Exterior texturing, through the use of brick, stone, or stucco, together with the half-timbering and asymmetrical massing, gives a Tudor Revival style building a picturesque composition. Character-defining features:

- » Half-Timbering
- » Steeply-Pitched Roof
- » Casement Windows with Mullions
- » Clipped Gables
- » Combination Hipped and Gabled Roof
- » Decorative Chimney Detailing
- » Stoop Entry
- » Heavy Shingles in Tile or Slate
- » Textured Exterior

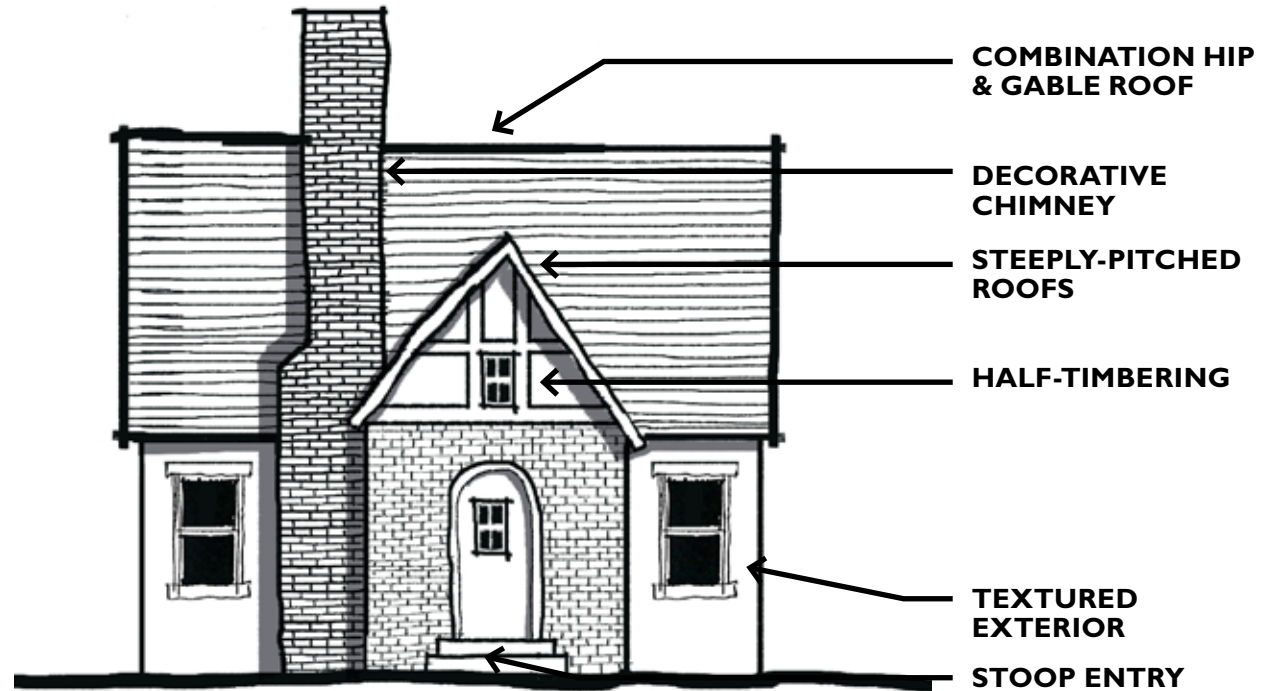

DUTCH REVIVAL (C. 1900-1925)

The gambrel roof is the distinguishing feature of the Dutch Colonial Revival. Primarily a residential style, it was popular in Colorado between 1900 and 1925. Other characteristic elements included wide overhangs, dormers, and a porch under the overhanging eaves of the gambrel roof, supported by columns.

- » Gambrel Roof
- » Wide Overhangs
- » Gable End Chimneys
- » Steep Stepped Gable
- » Porch Under Overhanging Eaves
- » Dormers

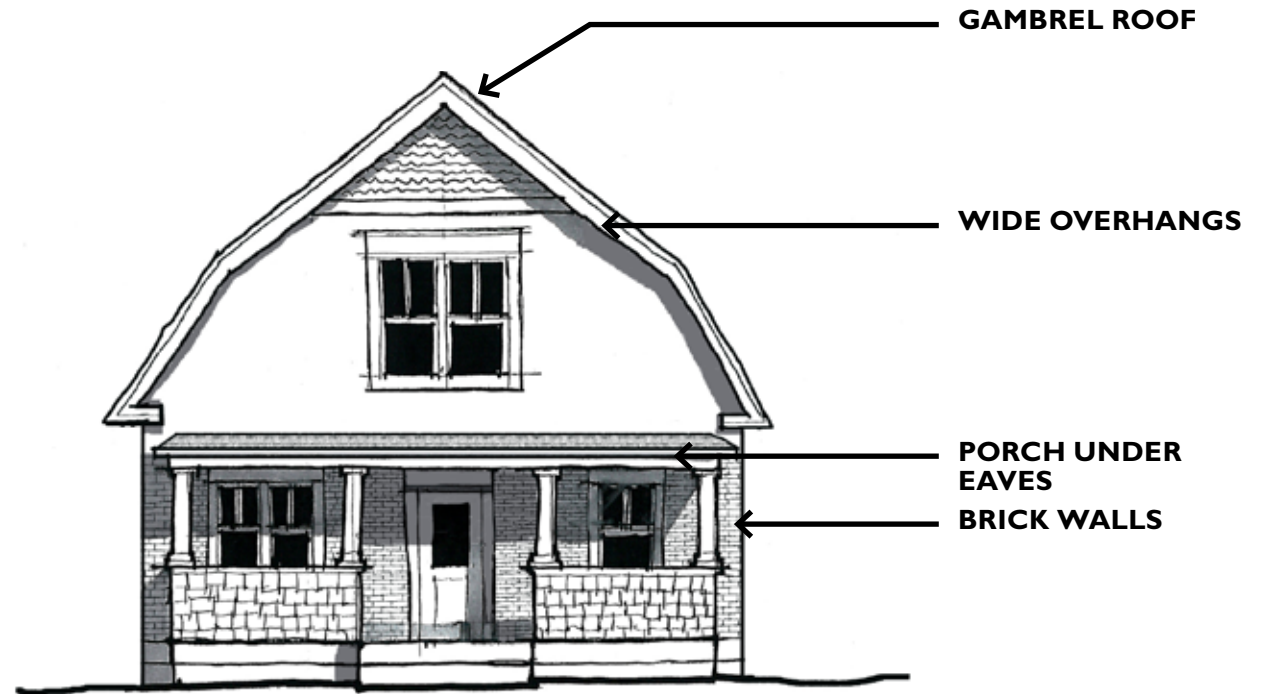

MINIMAL TRADITIONAL (C. 1930-9050)

These simple homes were built in large numbers immediately preceding and following World War II; this form represented an economical choice for large tract-housing developments because they were inexpensive to construct. In the Minimal Traditional form, the narrow deep footprint of the bungalow or period cottage was transformed to a square, boxy plan with small rooms situated around a core.

- » Boxy Appearance
- » Minimal Architectural or Decorative Details
- » Usually One Story
- » Rectangular Plan
- » Low or Intermediate Pitched Roof
- » Simple Roof, Typically Side-Gabled
- » Closed Eaves (Little or No Overhang)
- » Front-Facing Gable Section
- » Stoop Entry

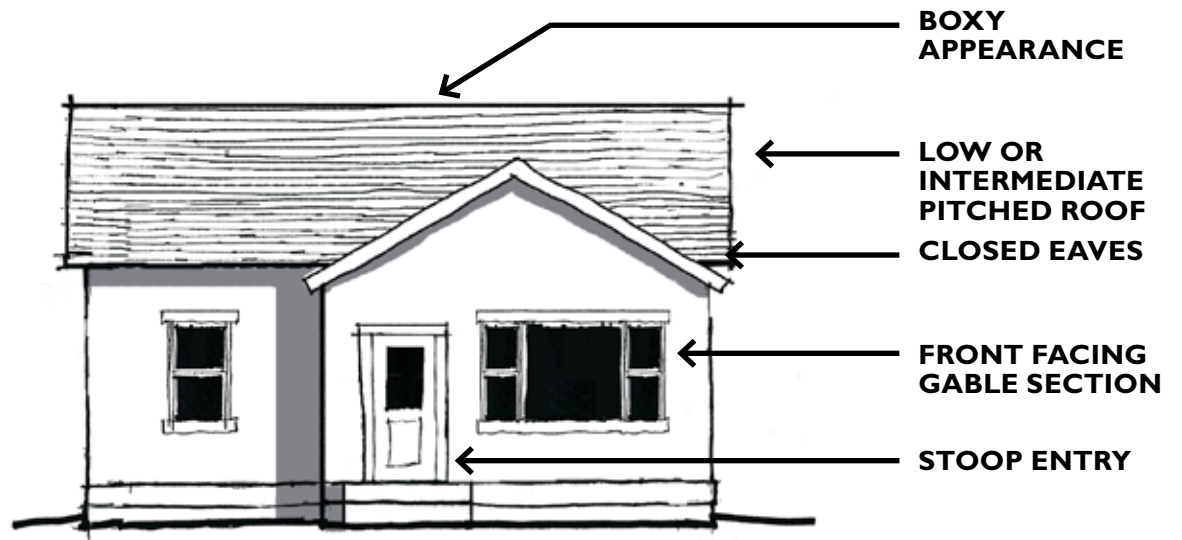

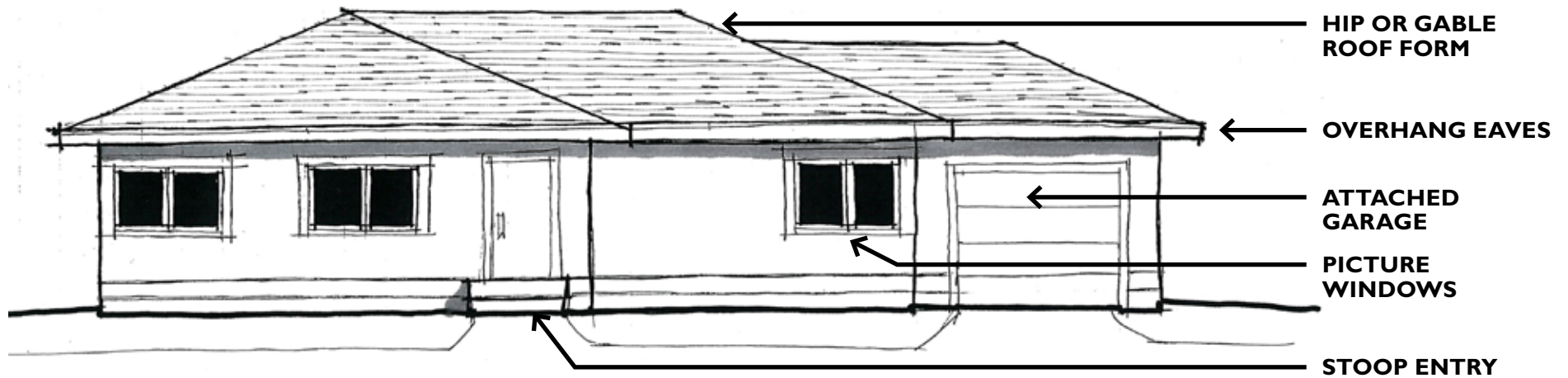

RANCH (C. 1940-1970)

By the late 1940s, Ranch houses were appearing in expanding suburbs and they came to dominate residential construction for several decades thereafter. The ranch house is noted for its long, close-to-the-ground profile, and wide open layout. This style is responsive to single family habitation and informal living spaces.

Character-defining features:

- » Primarily One-Story
- » Low Slope Hipped or Gabled Roof
- » Attached Garage
- » Stoop Entry
- » Brick and/or Wood Frame
- » Stucco, Brick, or Wood Exterior Material
- » Large Overhang Eaves
- » Picture Windows



CHARACTER AREAS

While the Old Town Neighborhoods exhibit many features that may be considered universal, there are in fact distinct differences in development patterns that exist in particular areas. These differing characteristics are important to consider when developing a design for new construction that will be compatible with its context.

Some character areas, for example, have a very consistent range of building sizes, or lot coverage percentages. In other places, diversity exists, but within a defined range. Other variables, including building height, building size, lot size and building age contribute to the differing areas. Those variables were considered in setting forth the different character areas that are described in this section. For more detailed information see the Appendix on page 99 for the Character Area Summary Charts.

The following neighborhood character area descriptions establish a clear understanding of the characteristics of an area that are valued by residents. This includes the basic physical framework of a neighborhood, similarities of design, and a description of the degree and types of diversity that appear in the character area. This analysis helps determine how best to apply the Design Guidelines to proposed improvements to ensure that neighborhood compatibility is maintained. A total of six distinct character area types were defined in the Old Town Neighborhoods.

ABOUT THE CHARACTER AREA BOUNDARIES

The maps that identify the location of the character areas use a hard line, which follows the edges of streets, alleys and property lines. But these boundaries may in some cases be more “fuzzy,” where transitions in character occur. In this sense, the boundaries help to define general concentrations of distinctive characteristics, but should not be considered to be definite, in contrast to zoning boundary lines.

USING THE CHARACTER ANALYSIS INFORMATION

Many qualitative features of the Old Town Neighborhoods are described for the individual Character Areas in this section. In addition, some statistical information is provided in the Appendix (pg. 102). The data is presented for each Character Area and shows the range of distribution of certain measurable factors.

- Neighborhood Character Areas**
- Character Area 1
 - Character Area 2
 - Character Area 3
 - Character Area 4
 - Character Area 5
 - Character Area 6

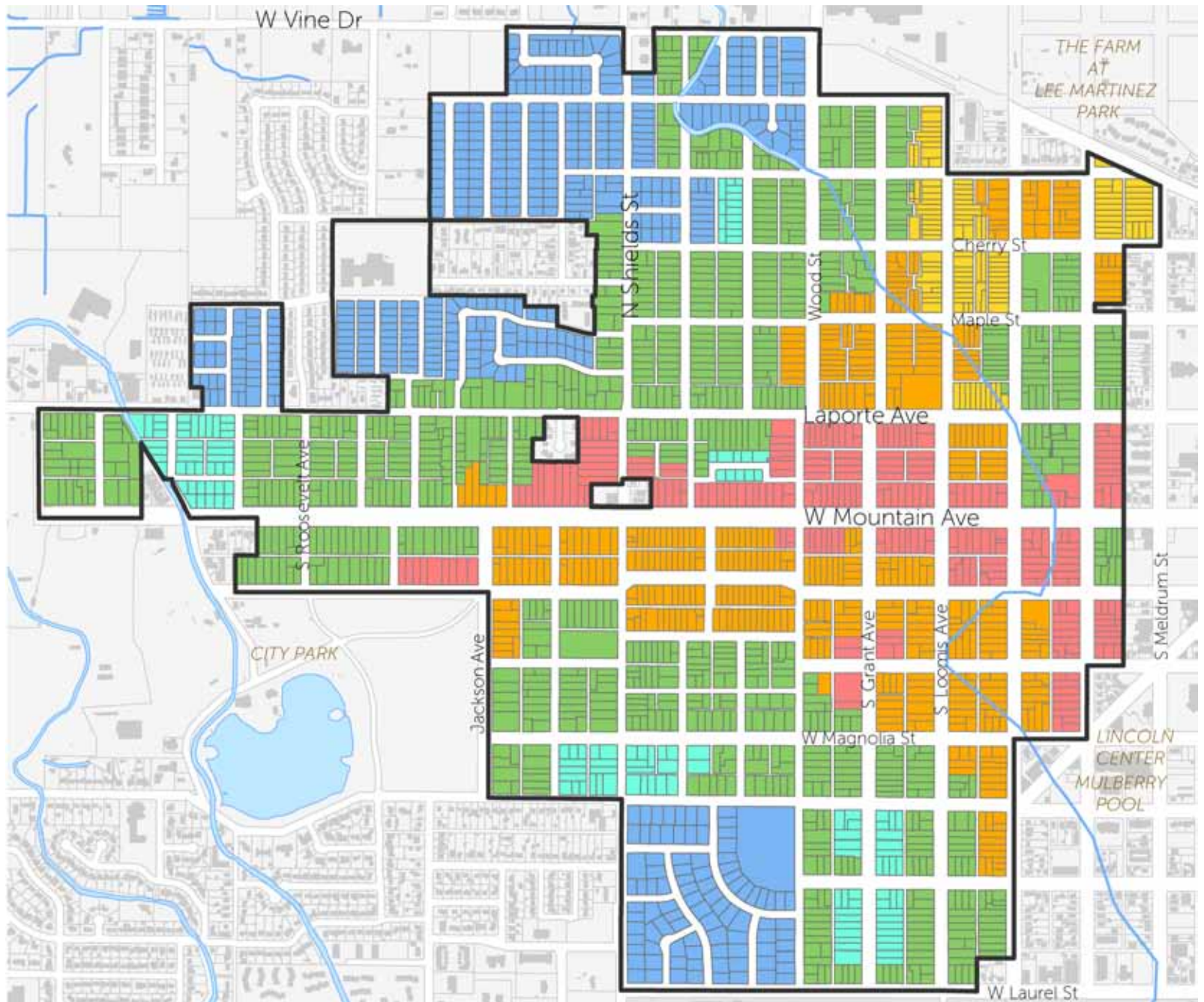

EASTSIDE NEIGHBORHOOD CHARACTER AREA MAP - EAST OF COLLEGE AVE

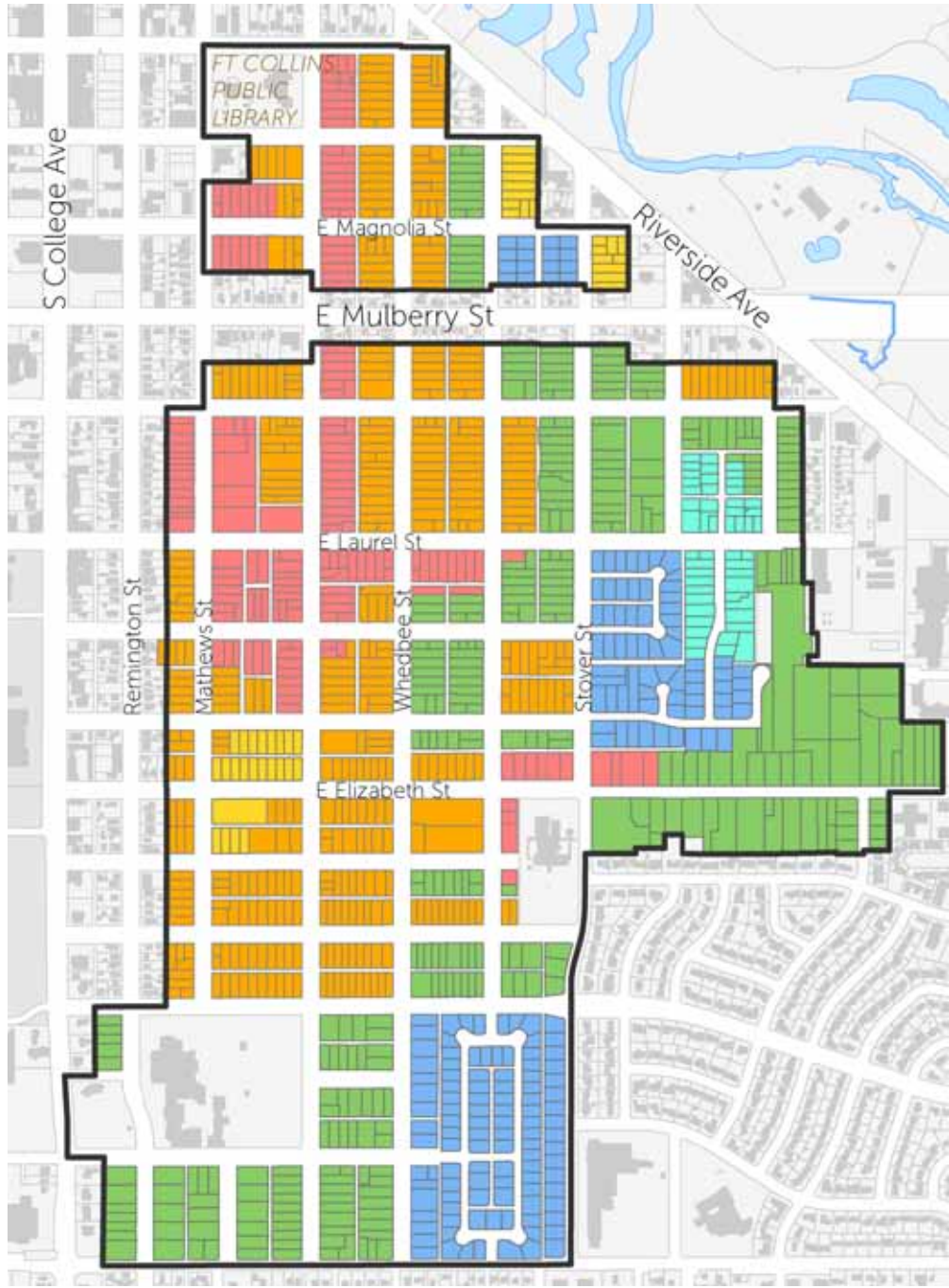

- Neighborhood Character Areas**
- Character Area 1
 - Character Area 2
 - Character Area 3
 - Character Area 4
 - Character Area 5
 - Character Area 6

CHARACTER AREA I

Description:

This character area includes portions of the neighborhoods with richly-detailed homes that are somewhat larger in scale than those found in other parts of the Old Town Neighborhoods. Much of the portion of Mountain Avenue that is close to Old Town is an example.

KEY FEATURES

- › Homes typically date from 1882-1920.
- › Richly-detailed homes with full or nearly full width front porches
- › Building scale and style are typically consistent within individual blocks.
- › Variety in home scales within character area, with largest typical building size (height and square footage)
- › 1, 1.5, and 2-story homes typical
- › Large variety in lot sizes with largest typical lot size overall

LOCATION

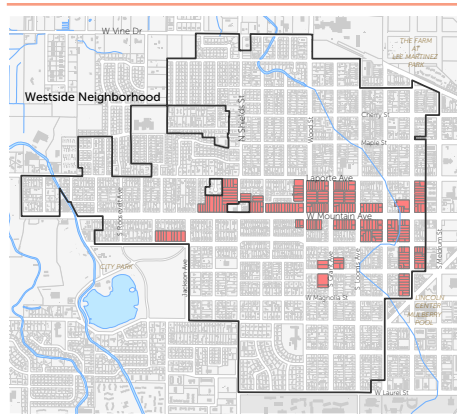

Figure 2: Old Town Character Area Map - West of College Avenue

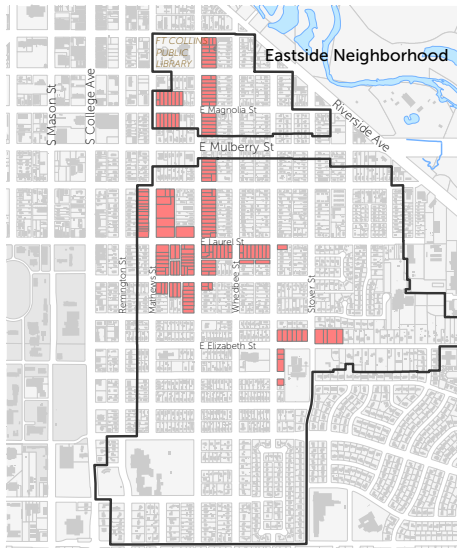

Figure 3: Old Town Character Area Map - East of College Avenue

SITE FEATURES



Figure 4: Aerial Image of Character Area I



Figure 5: Building Figure Ground Map of Character Area I. Uniform front yard setbacks occur along a block face (highlighted in green).



Figure 6: Character Area I includes portions of the neighborhoods with richly-detailed homes that are somewhat larger in scale than those found in other parts of the Old Town Neighborhoods. The alignment of one-story porches along the street is also a key characteristic of the neighborhood.

CHARACTER AREA I

ARCHITECTURAL STYLES

- › Queen Anne
- › Classic Cottage
- › Vernacular
- › Craftsman

SITE FEATURES

- › Uniform front yard setbacks
- › Lawns are predominant.
- › Fences or site wall occur infrequently, and are low in scale.
- › Lot sizes vary between blocks but are more consistent within an individual block face.
- › Combined side yards are typically 10 or more feet.

BUILDING SCALE FEATURES

Just less than half of homes are one story. Many primary structures are also one-and-a-half stories with the upper floors expressed with dormer windows; some are a full two stories. A typical house has a substantial, one-story front porch, which when aligned with others along the block, establishes a consistent sense of scale, even when the overall building heights vary. Building sizes vary widely.



Figure 7: Character Area I Classic Cottage



Figure 8: Character Area I Queen Anne



Figure 9: Character Area I Vernacular with an altered porch and Craftsman detailing at the eave



Figure 10: Character Area I rehabilitated cottage and vernacular two-story residences



Figure 11: Character Area I Queen Anne with Italianate detailing and addition. In this case, it would have been more appropriate to set back the addition from the front facade.

ARCHITECTURAL FEATURES

- › Most homes have sloping roof forms, in a mix of gable and hip shapes.
- › A combination of brick and wood siding. Many homes include both materials.
- › Front entries are defined with porches, and these are relatively large and in proportion to the building.
- › Trim details with contrasting colors add a sense of scale and provide visual interest.
- › As some of the earliest parts of the neighborhoods, a general consistency exists in building age (typically before 1920).

CHARACTER AREA 2

Description:

Most of the homes in this character area were built prior to 1940, and their sizes are in a “middle” range with respect to the Old Town Neighborhoods as a whole. Homes exhibit a moderate to high degree of architectural details, which contribute to a sense of scale. Building and lot characteristics can vary within each area. However, individual blocks are more consistent. Some larger-scale homes are located on corner lots in these areas.

Character Area 2 is similar to Character Area 4, but with a greater level of consistency in building styles and lot and building sizes.

KEY FEATURES

- › Homes typically date from 1901-1920.
- › Home have a moderate to high degree of architectural details.
- › Building scale and style are typically consistent within individual blocks.
- › Front entries are defined with large porches.
- › Home and lot sizes are in a “middle” range, with respect to the neighborhoods as a whole.
- › 1-1.5 story homes typical

LOCATION

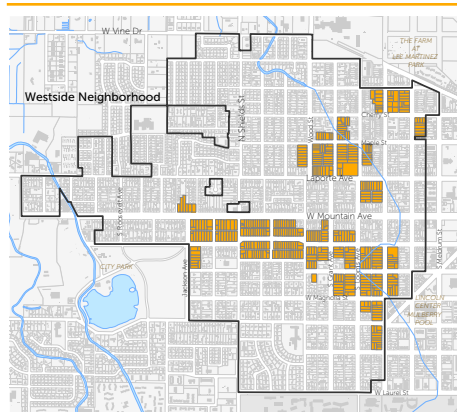

Figure 12: Old Town Character Area Map - West of College Avenue

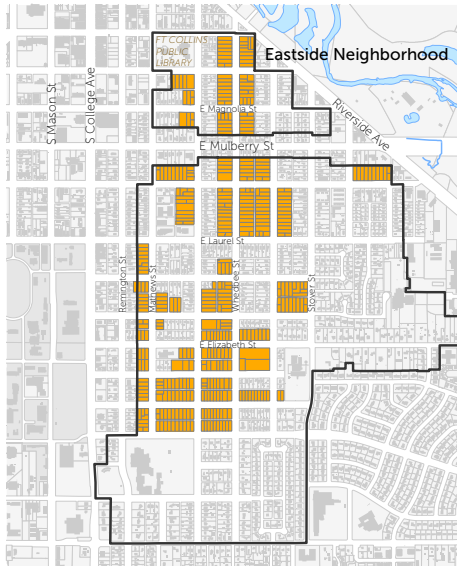

Figure 14: Old Town Character Area Map - East of College Avenue

SITE FEATURES



Figure 13: Aerial Image of Character Area 2



Figure 15: Building Figure Ground Map of Character Area 2. Uniform front yard setbacks occur along a block face (highlighted in green).

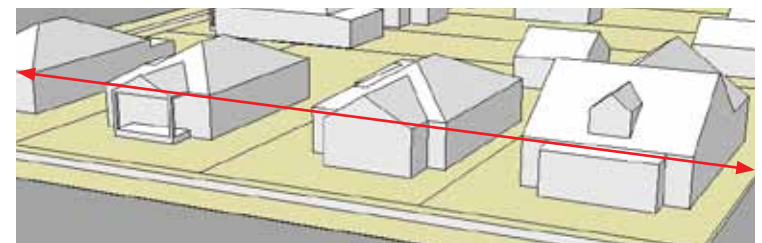

Figure 16: Most homes in Character Area 2 were built prior to 1945, and are in the “middle” range of building size with respect to the Old Town Neighborhoods at large. The alignment of one-story porches along the street is also a key characteristic of the neighborhood.

CHARACTER AREA 2

ARCHITECTURAL STYLES

- › Craftsman
- › Classic Cottage
- › Vernacular
- › Bungalow

SITE FEATURES

- › Uniform front yard setbacks
- › Prominent street wall
- › Lawns are predominant.
- › Fences or site wall occur infrequently, and are low in scale.
- › Lot sizes and widths are in a “middle” range
- › Combined side yards vary in width.

BUILDING SCALE FEATURES

Many primary structures are one- to one-and-a-half stories with the upper floors expressed with dormer windows. A small percentage are a full two stories. A typical house has a substantial one-story front porch, which when aligned with others along the block, establishes a consistent sense of scale, even when the overall building heights vary.



Figure 17: Character Area 2 A variety of roof forms occur along the street.



Figure 18: Character Area 2 A variety of building heights occur along the street.



Figure 19: Character Area 2 Uniform front yard setbacks are a strong site feature in the area.

ARCHITECTURAL FEATURES

- › Most homes have sloping roof forms, in a mix of gable and hip shapes.
- › A combination of brick and wood siding. Many homes include both materials.
- › Front entries are defined with porches, and these are relatively large and in proportion to the building.
- › A general consistency exists in building age before 1940. (Many are between 1901 and 1920.)

CHARACTER AREA 3

Description:

This character area includes homes with the lowest typical building scale. These are generally small pockets of development with very distinct character. Architectural details are more limited than in other areas, though they still help establish a sense of human scale. Homes appear consistent in character and size across one or more block faces. The majority of homes in these areas are predominantly one story, with a limited number of one-and-a-half and two-story structures.

Many primary structures are one- to one-and-a-half stories with the upper floors expressed with dormer windows. A small percentage are a full two stories. A typical house has a substantial one-story front porch, which when aligned with others along the block, establishes a consistent sense of scale, even when the overall building heights vary.

KEY FEATURES

- › Homes typically date from 1881-1920.
- › Architectural details are more limited but help establish a sense of human scale.
- › Building scale and style are typically consistent within individual blocks.
- › Front entries are defined with moderate porches.
- › Home and lot sizes are in a “middle” range, with respect to the neighborhoods as a whole.
- › One story homes predominate.

LOCATION

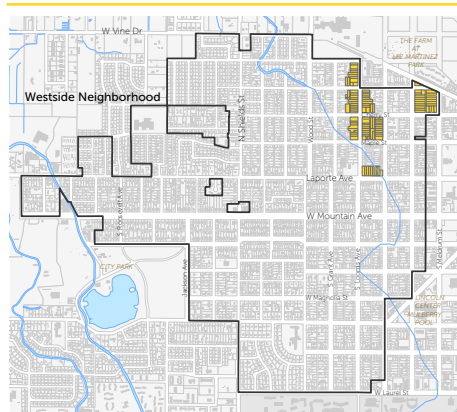

Figure 20: Old Town Character Area Map - West of College Avenue

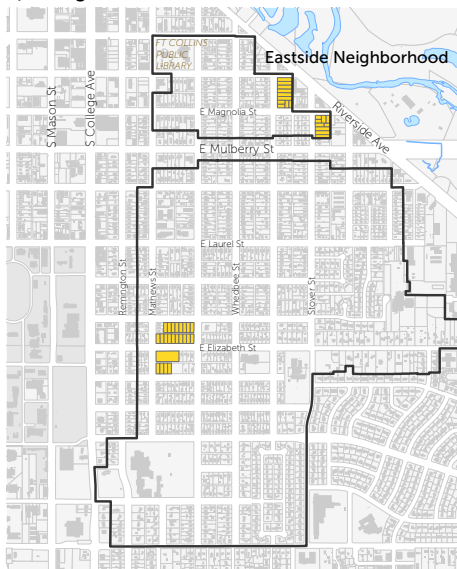

Figure 22: Old Town Character Area Map - East of College Avenue

SITE FEATURES



Figure 21: Aerial Image of Character Area 3

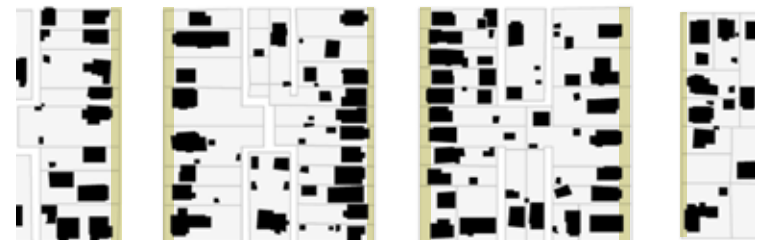

Figure 23: Building Figure Ground Map of Character Area 3. Uniform front yard setbacks occur along a block face (highlighted in green).

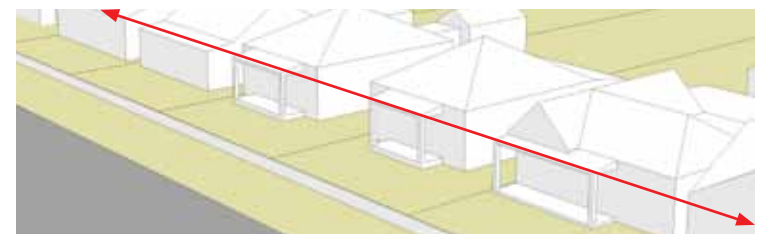

Figure 24: A typical house in Character Area 3 has a moderate, one-story front porch, which when aligned with others along the block, establishes a consistent sense of scale. The alignment of one-story porches along the street is also a key characteristic of the neighborhood.

CHARACTER AREA 3

ARCHITECTURAL STYLES

- › Minimal Traditional
- › Classic Cottage
- › Vernacular

SITE FEATURES

- › Building fronts generally align and front yards are similar in depth.
- › Prominent street wall
- › Lawns are predominant.
- › Fences or site wall occur infrequently, and are low in scale.
- › Lot sizes and widths are small.
- › Combined side yards are varied.

BUILDING SCALE FEATURES

Many primary structures are one story. A limited number are one-and-a-half stories with the upper floors expressed with dormer windows. A typical house has a moderate, one-story front porch, which when aligned with others along the block, establishes a consistent sense of scale. Home size is small relative to the Old Town Neighborhoods as a whole.



Figure 25: Character Area 3 Minimal Traditional



Figure 26: Character Area 3 Classic Cottage



Figure 29: Character Area 3 with hints of Tudor building form



Figure 27: Character Area 3 Vernacular - L Cottage



Figure 28: Character Area 3 modified Minimal Traditional

ARCHITECTURAL FEATURES

- › Most homes have sloping roof forms, in a mix of gable and hip shapes.
- › A combination of brick and wood siding. Many homes include both materials.
- › Front entries are defined with moderate porches in proportion to the building front.
- › Building age is varied within a narrow range (1881-1920).
- › There have been few remodels in this area; architectural character is consistent throughout.

CHARACTER AREA 4

Description:

In these areas there is no dominant style, rather the full variety of development in the neighborhoods is represented. Homes date from early development of the neighborhoods through to the mid-twentieth century. There is a large variety in building style and form across individual blocks in these areas. However, the homes are all of a similar scale with a moderate level of detailing. These areas have a greater degree of diversity, in terms of building age, scale and architectural styles and character than others. This character area category includes large portions of the Old Town Neighborhoods.

These areas are similar in scale to those of Character Area 2, but with a much greater diversity in lot and building characteristics and house styles.

KEY FEATURES

- › Homes typically date from 1901-1960.
- › Homes have a moderate to high degree of architectural details.
- › Front entries are defined with moderate porches.
- › Building scale is typically consistent within individual blocks.
- › Building style varies widely within individual blocks.
- › Home and lot sizes are small with respect to the neighborhoods as a whole.
- › Side setbacks allow sunshine into windows of neighboring homes.
- › One-story homes predominate, 1.5 and 2 story homes are also typical.

LOCATION

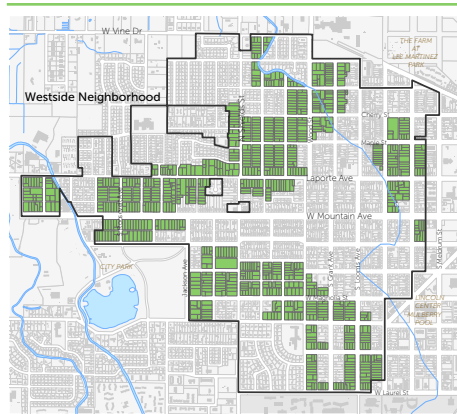

Figure 30: Old Town Character Area Map - West of College Avenue

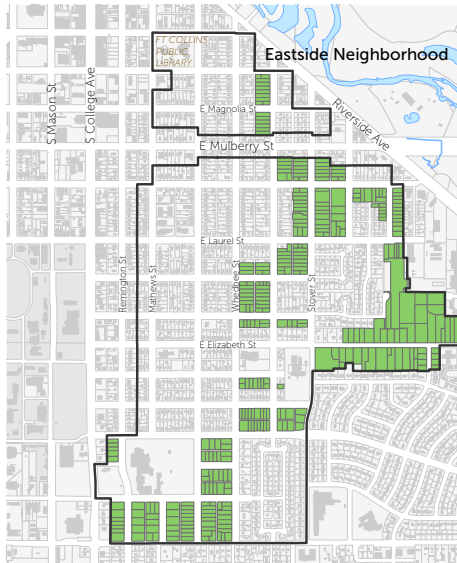

Figure 32: Old Town Character Area Map - East of College Avenue

SITE FEATURES



Figure 31: Aerial Image of Character Area 4



Figure 33: Building Figure Ground Map of Character Area 4. Uniform front yard setbacks occur along a block face (highlighted in green).

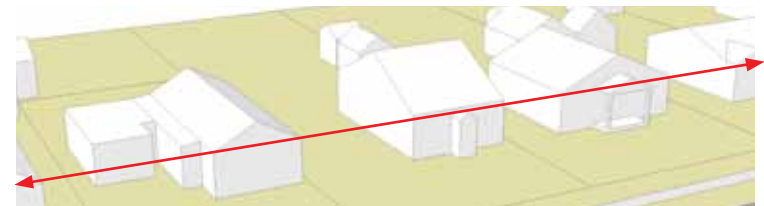

Figure 34: There is a large variety in building style and form across individual blocks in Character Area 4. The alignment of one-story porches along the street is also a key characteristic of the neighborhood.

CHARACTER AREA 4

ARCHITECTURAL STYLES

- › Minimal Traditional
- › Vernacular
- › Classic Cottage

SITE FEATURES

- › Building fronts generally align and front yards are similar in depth.
- › Prominent street wall
- › Lawns are predominant.
- › Fences or site wall occur infrequently, and are low in scale.
- › Side setbacks allow for significant sun exposure.
- › Large lot sizes compared to other areas
- › Combined side yards are generous.

BUILDING SCALE FEATURES

The majority of homes are one story. A small percentage of primary structures are also one-and-a-half stories, with the upper floors expressed with dormer windows, or they are a full two stories. Building sizes are in a “middle” range, with respect to the Old Town Neighborhoods as a whole.

ARCHITECTURAL FEATURES

- › Most homes have sloping roof forms, in a mix of gable and hip shapes.
- › Primarily frame construction
- › Front entries are defined with porches in proportion to the building.
- › More diversity in character; built throughout 1901-1960



Figure 35: Character Area 4 variety of one-story buildings with generous side yard setbacks.



Figure 36: Character Area 4 Minimal Traditional



Figure 37: Character Area 4 variety of altered one-story buildings; the building on the right has been altered inappropriately with the addition of a deck and the removal of the porch.



Figure 38: Character Area 4 Craftsman; the addition and some of the modifications on the building to the right are inappropriate.



Figure 39: Character Area 4 Craftsman in the foreground has been appropriately rehabilitated. Note the retention of building fabric and detailing.

CHARACTER AREA 5

Description:

This character area represents the post-war home styles built in areas with older lot and block patterns. Homes are typically one story, with minimal detailing. Due to older lot shapes being narrow and deep, homes tend to be rectangular with street-facing front-gable roofs. These areas exhibit a relatively high degree of consistency in overall development patterns and building characteristics. These are small, distinct enclaves.

These areas are similar in scale to Areas 2 and 4, but have distinct building patterns and styles unique to the time period they were built.

KEY FEATURES

- › Homes typically date from 1941-1960.
- › Architectural details are more limited but help establish a sense of human scale.
- › Building scale is typically consistent within individual blocks.
- › Front entries are defined with small porches or landings.
- › Home and lot sizes are small to middle range, with respect to the neighborhoods as a whole.
- › One-story homes predominate.

LOCATION

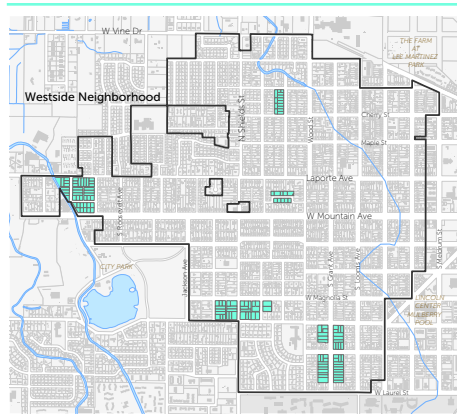

Figure 40: Old Town Character Area Map - West of College Avenue

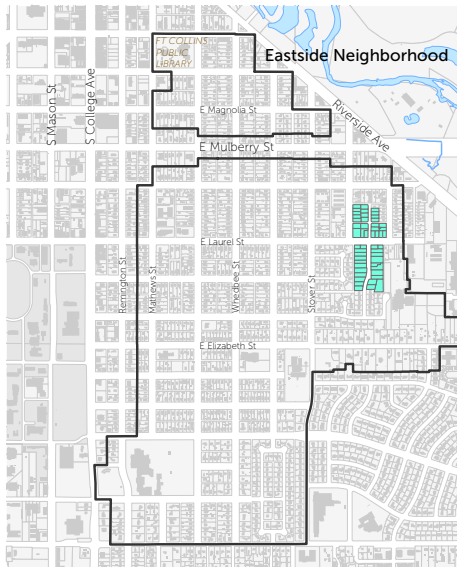

Figure 42: Old Town Character Area Map - East of College Avenue

SITE FEATURES



Figure 41: Aerial Image of Character Area 5



Figure 43: Building Figure Ground Map of Character Area 5. Uniform front yard setbacks occur along a block face (highlighted in green).

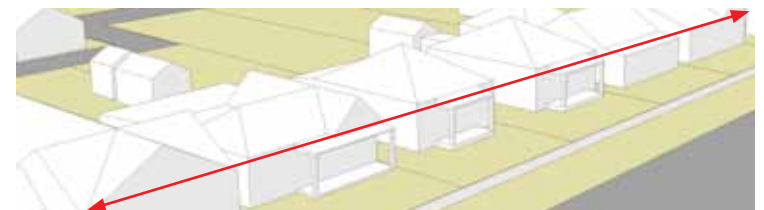

Figure 44: Character Area 5 includes primarily one-story post-war home styles on narrow, deep lots. The alignment of one-story porches along the street is also a key characteristic of the neighborhood.

CHARACTER AREA 5

ARCHITECTURAL STYLES

- › Minimal Traditional
- › Vernacular

SITE FEATURES

- › Building fronts generally align and front yards are similar in depth.
- › Street wall is predominant.
- › Lawns are predominant.
- › Fences or site wall occur infrequently, and are low in scale.
- › Combined side yards are varied.

BUILDING SCALE FEATURES

Most primary structures are one story and have small footprints. A typical house has a moderate one-story front porch or stoop. Building fronts align with others along the block, establishing a consistent sense of scale. Most houses have very small footprints, well under 1,000 square feet.



Figure 45: Character Area 5 Minimal Traditional with low sloping roof



Figure 46: Character Area 5 modified Minimal Traditional. Low site wall feature



Figure 47: Character Area 5 modified Minimal Traditional

ARCHITECTURAL FEATURES

- › Most homes have low sloping roof forms, in a mix of gable and hip shapes.
- › A combination of brick and wood siding. Many homes include both materials.
- › Front entries are defined with porches or landings which are relatively small in proportion to the building.
- › A high level of consistency exists in building age (predominantly between 1941 and 1960).

CHARACTER AREA 6

Description:

This character area includes the mid-century modern subdivisions. Ranch style homes predominate, typically with limited, simple detailing, and rectangular forms with shallow roofs running parallel to the street. Houses are predominately one story in height, with a few split-level homes, and are low to medium scale. Street patterns include cul-de-sacs and curvilinear layouts, with no alleys and wide, shallow lots.

KEY FEATURES

- › Homes typically date from 1941-1960.
- › Architectural details are limited.
- › Building scale is typically consistent within individual blocks.
- › Front entries are defined with small landings.
- › Home and lot sizes are in a “middle” range, with respect to the neighborhoods as a whole.
- › Lot widths are largest relative to the neighborhoods as a whole.
- › One-story homes predominate

LOCATION

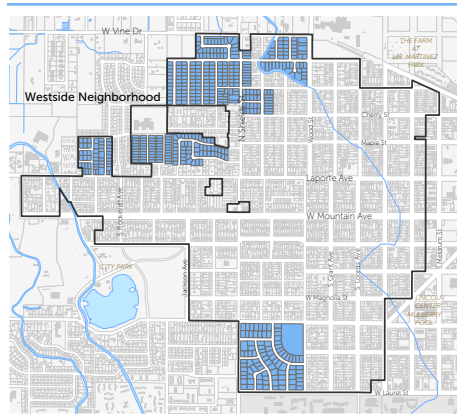

Figure 48: Old Town Character Area Map - West of College Avenue

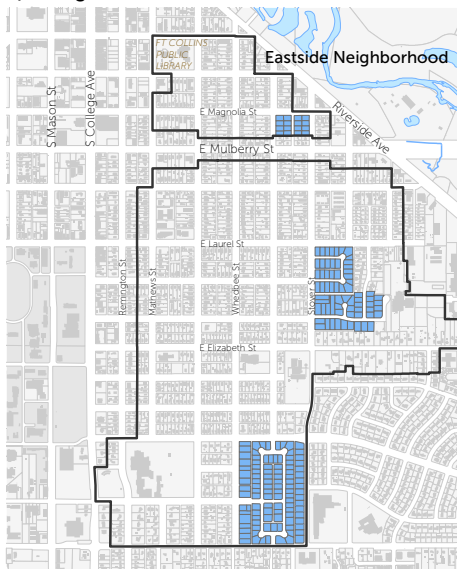

Figure 52: Old Town Character Area Map - East of College Avenue

SITE FEATURES



Figure 49: Aerial Image of Character Area 6



Figure 50: Building Figure Ground Map of Character Area 6. Uniform front yard setbacks occur along a block face (highlighted in green).



Figure 51: Ranch style homes predominate in Character Area 6, typically having limited, simple detailing, and rectangular forms with shallow roofs running parallel to the street. Building fronts generally align and front yards are similar in depth.

CHARACTER AREA 6

ARCHITECTURAL STYLES

- › Minimal Traditional
- › Ranch

SITE FEATURES

- › Building fronts generally align and front yards are similar in depth.
- › Street wall is predominant.
- › Lawns are predominant.
- › Fences or site wall occur infrequently, and are low in scale.
- › Combined side yards are 10 or more feet.

BUILDING SCALE FEATURES

Many primary structures are one story; others are split-level or a full two-story height. A typical house has a moderate stoop but typically does not have a porch. Building fronts align with others along the block, establishing a consistent sense of scale. Many buildings in these areas have been remodeled.

ARCHITECTURAL FEATURES

- › Most homes have low sloping roof forms, in a mix of gable and hip shapes.
- › A combination of brick and wood siding. Many homes include both materials.
- › Front entries are defined with landings, and these are relatively small in proportion to the building.
- › Very consistent in building age (typically between 1950 and 1970)



Figure 53: Character Area 6 Ranch with porch front addition



Figure 54: Character Area 6 Ranch with low sloping roof and attached garage



Figure 55: Character Area 6 Row of aligned Minimal Traditional homes with side driveways to parking in the rear



Figure 56: Character Area 6 Minimal Traditional



Figure 57: Character Area 6 Ranch with wide building fronts

3

DESIGN GUIDELINES FOR THE TREATMENT OF HISTORIC RESOURCES

Design Guidelines for the Treatment of Historic Resources

The City seeks to preserve the historic integrity of properties of historic significance in the Old Town Neighborhoods. This means employing best practices in property stewardship to maintain the key character-defining features of individual historic resources, as well as maintaining the character areas in which they exist.

What is historic preservation?

Preservation means having properties and places of historic and cultural value in active use and accommodating appropriate improvements to sustain their viability while maintaining the character-defining features which contribute to their significance as cultural resources. In addition historic preservation means keeping cultural resources intact for the benefit of future generations.

Why preserve historic properties?

Fort Collins' historic neighborhoods are essential components of the City's identity. They enhance the quality of life, economic vitality, and environmental sustainability. Investment in these assets ensures that the social, cultural and economic attraction of the City is maintained and enhanced.

This section provides guidelines for the treatment of historic properties in the Old Town Neighborhoods. It focuses on the rehabilitation and maintenance of historic properties.



Figure 59: One-and-a-half story gable front Vernacular.



Figure 60: One-story, cross gable roof Minimal Traditional residence.



Figure 61: One-story cottage homes are a common style throughout the Old Town Neighborhoods Character Areas.



Figure 62: Two-story Four Square with Italianate detailing.



Figure 63: Retain and treat exterior character-defining features and examples of skilled craftsmanship with sensitivity. Important features include turned columns, upper porch spindles and zipper brick corners.



Figure 64: Maintain significant character-defining features, including: projecting cornices, decorative moldings and brackets and dentils and shingle siding at dormer.

Maintaining Historic Materials

Primary historic building materials include masonry (brick, mortar, stone, and concrete), wood and metal. These should be preserved and repaired.

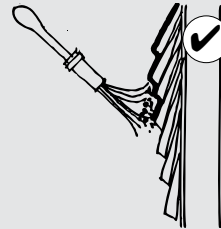

Appropriate treatments to protect specific materials from deterioration include:

Masonry

- › Maintain the natural water-protective layer (patina).
- › Do not paint, unless it was painted historically (this can seal in moisture, which may cause extensive damage over time).
- › Re-point deteriorated masonry mortar joints with mortar that matches the strength, composition, color style, and texture of the historic material.
- › If replacing damaged brick that cannot be saved, use bricks of same length, width, color, and height and apply them in the same pattern.

Wood

- › Maintain paint and other protective coatings to retard deterioration and ultraviolet damage.
- › Provide proper drainage and ventilation.

Metal

- › Maintain protective coatings, such as paint, on exposed metals.
- › Provide proper drainage.

GENERAL PRESERVATION PRINCIPLES

The following design guidelines translate the general principles for historic preservation for the treatment of individual buildings and site features that are typically found in the neighborhoods.

These design principles should be considered when making improvements to a historic property.

3.1 Respect the individual historic character of a property.

- › The basic form and materials of a building, as well as architectural details, reflect the design trends, available materials, local vernacular, and building techniques of a particular era that together make up each home's historic character.
- › *Restoration* returns a building to its original condition--a painstaking process typically reserved for buildings of exceptional historical and architectural significance.
- › *Rehabilitation* retains and repairs the valuable, character-defining features associated with the architectural style, while also allowing for sympathetic modernizing elements that maintain the visual integrity of the original building.
- › *Remodeling* constitutes alterations and building redesign that obliterate the basic character of the original architecture.

3.2 Seek new uses that are compatible with the historic character of the property.

- › Converting a building to a new use different from the historic use is considered to be an "adaptive reuse," and is a sound strategy for keeping an old building in service. For example, converting a residential structure

to offices is an adaptive reuse. A good adaptive reuse project retains the historic character of the building while accommodating a new function.

- › Every effort should be made to provide a compatible use for the building that will require minimal alteration to the building and its site.
- › Changes in use requiring the least alteration to significant elements are preferred. In most cases designs can be developed that respect the historic integrity of the building while also accommodating new functions.

3.3 Protect and maintain significant features and stylistic elements.

- › Character-defining features and other examples of skilled craftsmanship should be preserved. The best preservation procedure is to maintain historic features from the outset to prevent the need for repair later. Appropriate maintenance includes rust removal, caulking and repainting.
- › These features should not be removed.

Character-defining features

Typical character-defining features to preserve include:

- › Eaves
- › Windows and doors and surrounds
- › Surface ornamentation
- › Columns
- › Porches
- › Please see the Architectural Styles section that identifies character-defining features.



Figure 65: This palladian window with wood tracery is a character-defining feature that helps to convey the architectural style and should be preserved.

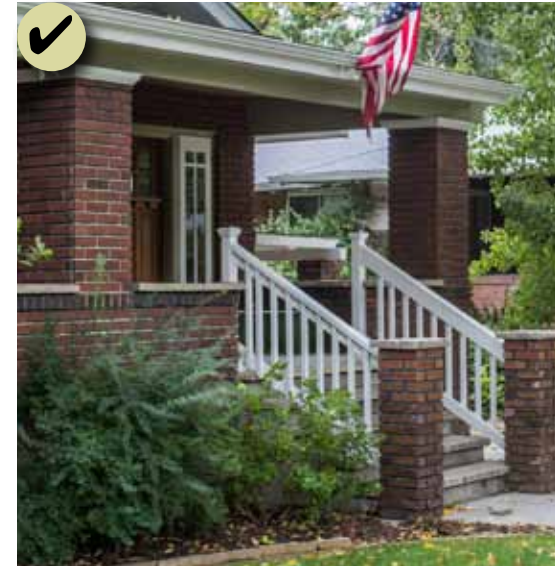

Figure 66: The thick, brick columns on this porch help to convey the architectural style and should be preserved.

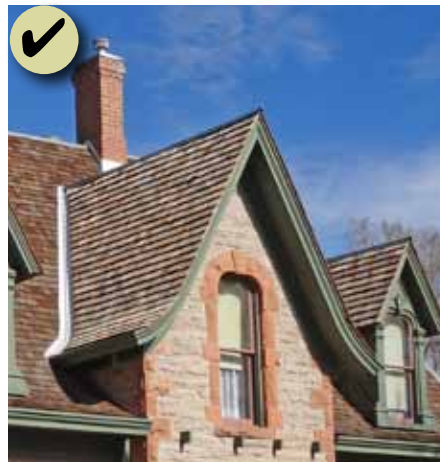

Figure 67: The corbeling, keystone detailing at windows and splayed roof eaves are character-defining features that help to convey the architectural style of the Avery House and should be preserved.



Figure 68: This reconstruction of a historic window maintains the significant features and stylistic elements that were present in the original construction of the building.



Figure 69: Do not remove damaged materials that can be repaired. In this case, loose shingles may be re-secured while missing ones may be replaced.

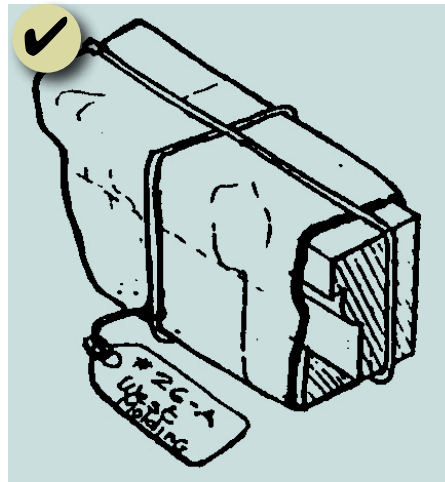

Figure 70: Document the location of a historic feature that must be removed and repaired so it may be repositioned accurately.



Figure 71: Before: A deteriorated railing should be repaired not replaced when feasible.



Figure 72: After: Railing has been repaired and the base of the post has been replaced in-kind. This is an appropriate approach.

CHARACTER-DEFINING FEATURES

Character-defining features help convey the historic and architectural significance of historic properties, and should be preserved. The method of preservation that requires the least intervention is expected.

3.4 Maintain character-defining features.

- › Retain and treat exterior character-defining features and examples of skilled craftsmanship with sensitivity.
- › Employ preventive maintenance measures such as caulking and repainting.

3.5 Repair, rather than replace, significant architectural details if they are damaged.

- › Do not remove or alter character-defining features that are in good condition or that can be repaired.
- › Document the location of a historic feature that must be removed to be repaired so it may be repositioned accurately.
- › Patch, piece-in, splice, consolidate or otherwise upgrade deteriorated features using recognized preservation methods.
- › When necessary, upgrade existing materials, using recognized preservation methods. If disassembly is necessary for repair or restoration, use methods that minimize damage to historic materials and facilitate reassembly.
- › Protect character-defining features that are adjacent to the area being worked on.



Figure 73: Replace missing original details in kind.

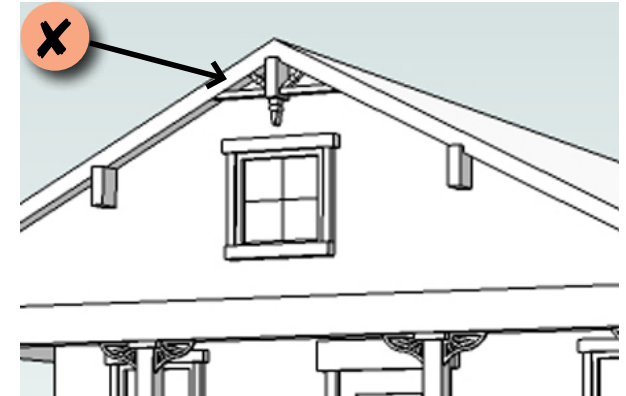

Figure 74: Do not add features that were not part of the historic structure. For example, decorative millwork shall not be added to a building if it was not a historic feature as doing so would convey a false history.

3.6 Reconstruct a character-defining feature if it cannot be repaired.

- › Use a design that is substantiated by physical or pictorial evidence to avoid creating a misrepresentation of the building's history.
- › Use the same kind of material as the historic feature. However, an alternative material may be considered if it:
 - › Has proven durability
 - › Has a size, shape, texture and finish that conveys the visual appearance of the historic feature
 - › Is located in a place that is remote from view or direct physical contact
- › Do not add features that were not part of the historic structure. For example, decorative millwork shall not be added to a building if it was not a historic feature as doing so would convey a false history.



Figure 75: When reconstruction of a historic feature is impossible, develop a new design that is a simplified interpretation of it. This detail in the porch bracketing has simple vertical and horizontal elements rather than the historic curvature detail.

For More Information

See web link to Preservation Brief 47: Maintaining the Exterior of Small and Medium Size Historic Buildings

<http://www.nps.gov/tps/how-to-preserve/briefs/47-maintaining-exteriors.htm>



Figure 76: Re-point mortar joints where there is evidence of deterioration. This shall match the historic design.

For More Information

See web link to *Preservation Brief 1: Assessing Cleaning and Water-Repellent Treatments for Historic Masonry Buildings*

<http://www.nps.gov/tps/how-to-preserve/briefs/1-cleaning-water-repellent.htm>

See web link to *Preservation Brief 2: Repointing Mortar Joints in Historic Masonry Buildings*

<http://www.nps.gov/tps/how-to-preserve/briefs/2-repoint-mortar-joints.htm>

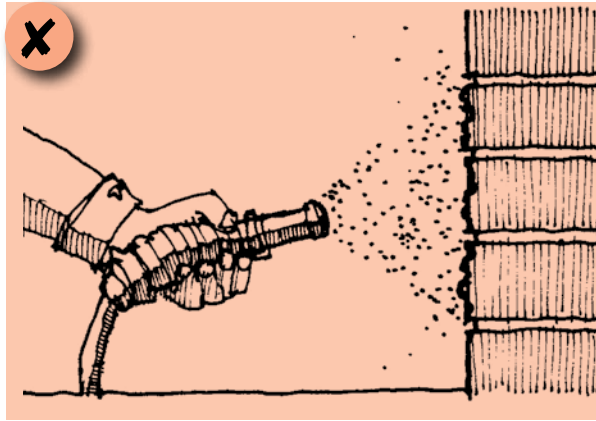

Figure 77: Do not use harsh cleaning methods, such as sandblasting, which can damage historic materials.

Alternative Window Material

If it is not possible to match the historic design and materials of a window, then an alternative design may be appropriate in the following locations:

- › On a non-primary façade, accessory building or addition
- › On a primary façade if no other option is available

Alternative window designs shall:

- › Match the general profile and details of the historic window.
- › Use materials that match the historic appearance in dimension, profile and finish.

MATERIALS AND FINISHES

Historic materials should be preserved in place. If the material is damaged, limited replacement to match the historic material should be considered. Historic building materials should never be covered or subjected to harsh cleaning treatments. Preserving historic building materials and limiting replacement to only pieces which are deteriorated beyond repair also reduces the demand for, and environmental impacts from, the production of new materials and therefore supports the city's sustainability objectives.

3.7 Maintain historic building materials.

- › Protect historic building materials from deterioration.
- › Do not remove historic materials that are in good condition.
- › Use a low pressure water wash if cleaning is permitted. Chemical cleaning may be considered if a test patch does not have a negative effect on the historic fabric (test patch should be reviewed by City preservation department).
- › Do not use harsh cleaning methods, which can inhibit the function and/or appearance of the historic material, (such as sandblasting, which can damage its protective coating).

3.8 Repair historic building materials when needed.

- › Repair deteriorated building materials by patching, piecing-in, consolidating, or otherwise reinforcing the material.
- › Replace only those materials that are deteriorated, and beyond reasonable repair.

3.9 Replace historic building materials in kind.

- › Use the same material as the historic material to replace damaged building materials.
- › Also use historic materials to replace damaged building materials on a non-primary façade.
- › Replace only the amount of material that is beyond repair.
- › Use only replacement materials that are similar in scale, finish and character to the historic material.
- › Use only replacement materials with proven durability.
- › Do not replace building materials, such as masonry and wood siding, with alternative or imitation materials, unless no other option is available.

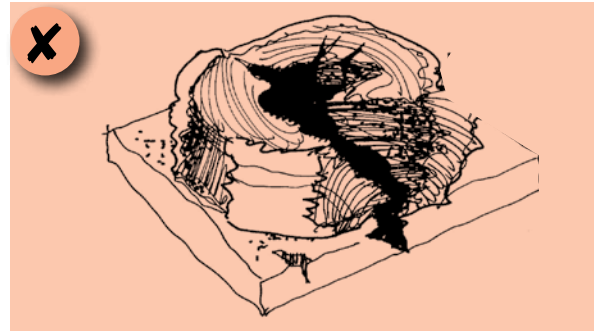

Figure 78: Consider removing later covering materials that have not achieved historic significance.

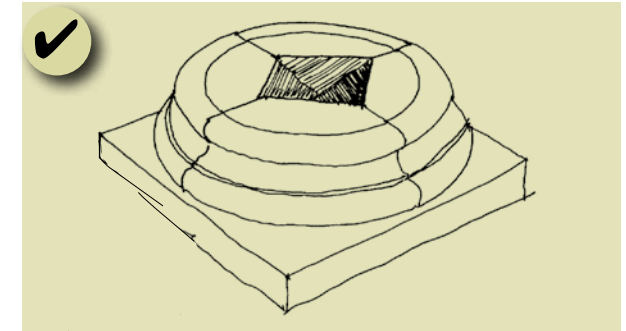

Figure 79: When necessary, upgrade existing materials, using recognized preservation methods.

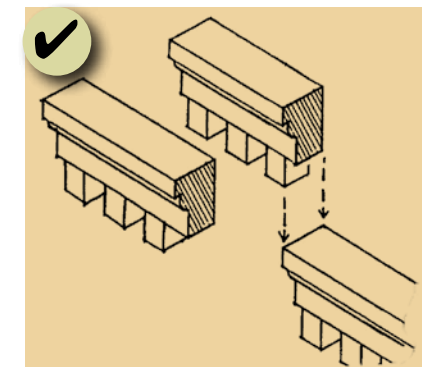

Figure 80: Patch, piece-in, splice, consolidate or otherwise upgrade deteriorated features using recognized preservation methods.

For More Information

See web link to *Preservation Brief 16: The Use of Substitute Materials on Historic Building Exteriors*.

<http://www.nps.gov/tps/how-to-preserve/briefs/16-substitute-materials.htm>



Figure 81: Repair and weatherization is often more energy efficient, and less expensive, than replacement.



Figure 82: Preserve historic window features including the frame, sash, muntins, mullions, moldings, glazing, sills, heads, jambs and groupings.



Figure 83: Historic windows help convey the significance of historic structures, and should be preserved.



Figure 84: Roof overhangs and eave details are important to maintain the character of the building.



Figure 85: This three pane window alteration is inappropriate and should be restored to its original historic configuration.



Figure 86: The windows and siding have both been inappropriately replaced with vinyl.

WINDOWS

Historic windows are very important character-defining features that help convey the significance of historic structures, and should be preserved. They can be repaired by re-glazing and patching and splicing elements such as muntins, the frame, sill and casing. Repair, weatherization, and installation of interior storm windows are more often than not the most energy efficient, and less expensive, solution. If a historic window cannot be repaired, a new replacement window should be in character with the historic building.

3.11 Maintain and repair historic windows.

- › Preserve all historic window features including the frame, sash, muntins, mullions, glazing, sills, heads, jambs, moldings, operation and groupings of windows.
- › Repair and maintain windows regularly, including trim, glazing putty and glass panes.
- › Repair, rather than replace, frames and sashes.
- › Restore altered window openings to their historic configuration.
- › If necessary, install interior storm windows to preserve exterior appearance.

3.12 Replace a historic window with a matching design if repair is not possible.

- › Replace with the same material.
- › Match the type of the historic window design (i.e., replace a casement window with a new casement window, or a double-hung window with a new double-hung window).
- › Maintain the historic size, shape and number of panes.
- › Match the profile of the sash, muntin and its components to the historic window, including the depth of the sash, which may step back to the plane of the glass in several increments.
- › Use clear window glazing that conveys the visual appearance of historic glazing (transparent low-e glass is preferred).
- › The use of vinyl and unfinished metals as window replacement materials is inappropriate.
- › The use of metallic or reflective window glazing is inappropriate.
- › To reduce a historic opening to accommodate a smaller window or increase it to accommodate a larger window is inappropriate.

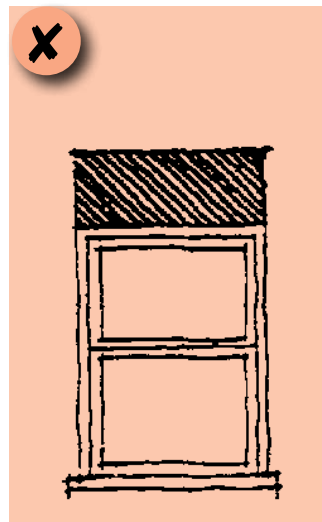
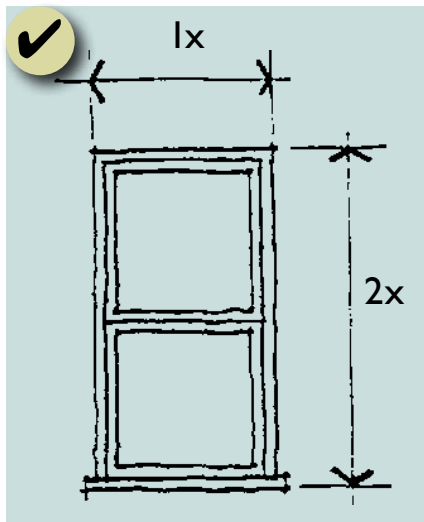

For More Information

See web link to *Preservation Brief 9: The Repair of Historic Wooden Windows*

<http://www.nps.gov/tps/how-to-preserve/briefs/9-wooden-windows.htm>

See web link to *Preservation Brief 13: The Repair and Thermal Upgrading of Historic Steel Windows*

<http://www.nps.gov/tps/how-to-preserve/briefs/13-steel-windows.htm>

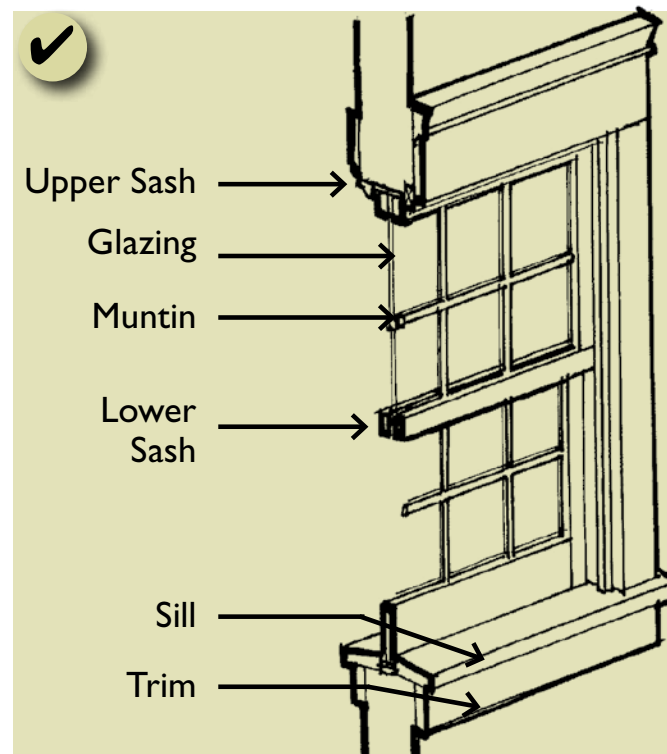

Figure 87: Double-hung window

Figure 88: Preserve the size and proportion of a historic window opening.

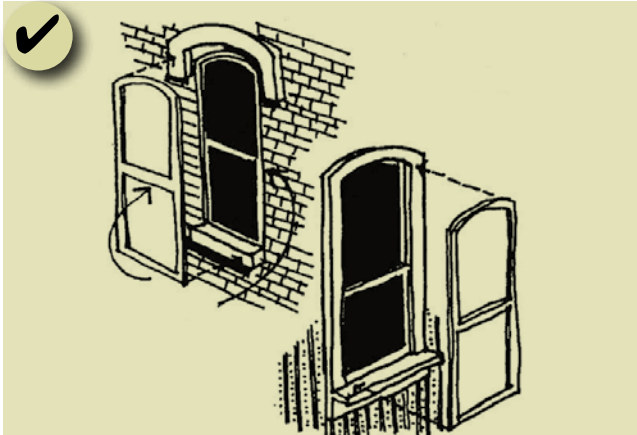

Figure 89: Place storm windows internally to avoid exterior visual impacts (right). Use storm window inserts designed to match the historic frame if placed externally (left).



Figure 91: The storm windows match the opening; however, it would be more appropriate if they were wood frames to match the original material.



Figure 90: Use storm windows designed to match the historic window frame if placed externally.



Figure 92: The storm windows match the opening; however, it would be more appropriate if the frames matched the historic window sash similar to the image shown above.

3.13 Use special care when replacing a window on a primary façade.

- › Give special attention to matching the historic design and materials of windows located on the primary or secondary façade.

3.14 Design a storm window to minimize its visual impacts.

- › If a window did not historically have a storm window, place a new storm window internally to avoid exterior visual impacts.
- › Use storm windows designed to match the historic window frame if placed externally.
- › Place a storm window internally to avoid the impact upon external appearance.
- › Use insect screens with painted wooden frames where wood windows exist.

3.15 Restore a historic window opening that has been altered.

- › Restore a historic window opening that previously existed.
- › Place a new window to fit within the historic opening.

For More Information

See web link to window retrofit article from the *National Trust for Historic Preservation* web site

<http://www.preservationnation.org/who-we-are/press-center/press-releases/2012/new-windows-study.html>

Web link to window treatments *National Park Service Tech Notes*. Scroll down page to window to secure links

<http://www.nps.gov/tps/how-to-preserve/tech-notes.htm>

3.16 When necessary, locate and design a new window opening to preserve the overall rhythm and arrangement of windows on a secondary building wall.

- › Locate a new window opening to match the general arrangement of historic windows in a building wall.
- › Design a new window opening to match historic window proportions on the same façade.

3.17 Enhance the energy efficiency of historic windows and doors.

- › Make the best use of historic windows; keep them in good repair and seal all the leaks.
- › Maintain the glazing compound regularly. Remove old putty with care.



Figure 93: Design a new window opening to match historic window proportions on the same façade. The image above illustrates the historic building. The image below shows an appropriate location for a new window in the historic building.

DOORS AND ENTRIES

The design, materials and location of historic doors and entries help establish the significance of a historic structure and should be preserved. When a new door is needed, it should be in character with the building.

3.18 Maintain a historic primary entrance.

- › Preserve historic and decorative features, including door frames, sills, heads, jambs, moldings, detailing, transoms and flanking sidelights.
- › Do not alter the historic size and shape of a historic door opening.
- › Do not change the historic locations of door openings on primary façades.
- › Do not add a new door opening on a primary façade.

3.19 Repair or replace a damaged door to maintain its general historic appearance.

- › Use materials that are similar to that of the historic door.
- › When replacing a historic door on a primary façade, use a design that is similar to the historic door.
- › When replacing a historic door on a non-primary façade, use a design that is in character.

3.20 Locate and design a new door and entry to preserve the historic composition.

- › Locate a new door to be consistent with the historic architectural style of the structure.
- › Design a new door or entry to match historic door proportions.



Figure 94: When necessary, a simple wood half-glazed door with paneling below is an appropriate replacement door for many of the modest historic styles.



Figure 95: Simple wood screen doors are appropriate additions.



Figure 96: Simple wood screen doors are appropriate additions.



Figure 97: This three-pane replacement door is not typical for most of the historic styles located within the neighborhoods. A simple single-pane window door should be used.



Figure 98: This simple door design complements the minimal traditional building form.

PORCHES, DECKS AND BALCONIES

Preserve a porch in its original condition and form. A porch is one of the most important character-defining features of a façade. A porch provides visual interest to a building and shelter from the elements. It also defines building scale and establishes social hierarchy of space from the street to the house interior.

Decks and balconies on residential buildings weren't traditionally found in the Old Town Neighborhoods. Adding them to the front of a historic building impacts its existing architectural style and character.

3.21 Preserve an original porch or stoop.

- › Preserve the existing height, location, shape, details and posts of the porch.
- › Do not remove an original porch from a building.
- › Avoid enclosing a historic porch, particularly on a highly-visible façade.

3.22 If necessary, repair or replace damaged porch features.

- › Replace missing features and repair damaged features to match existing historic features.
- › Maintain the overall composition when replacing porch features (i.e., when replacing balusters, match the original proportions and spacing).

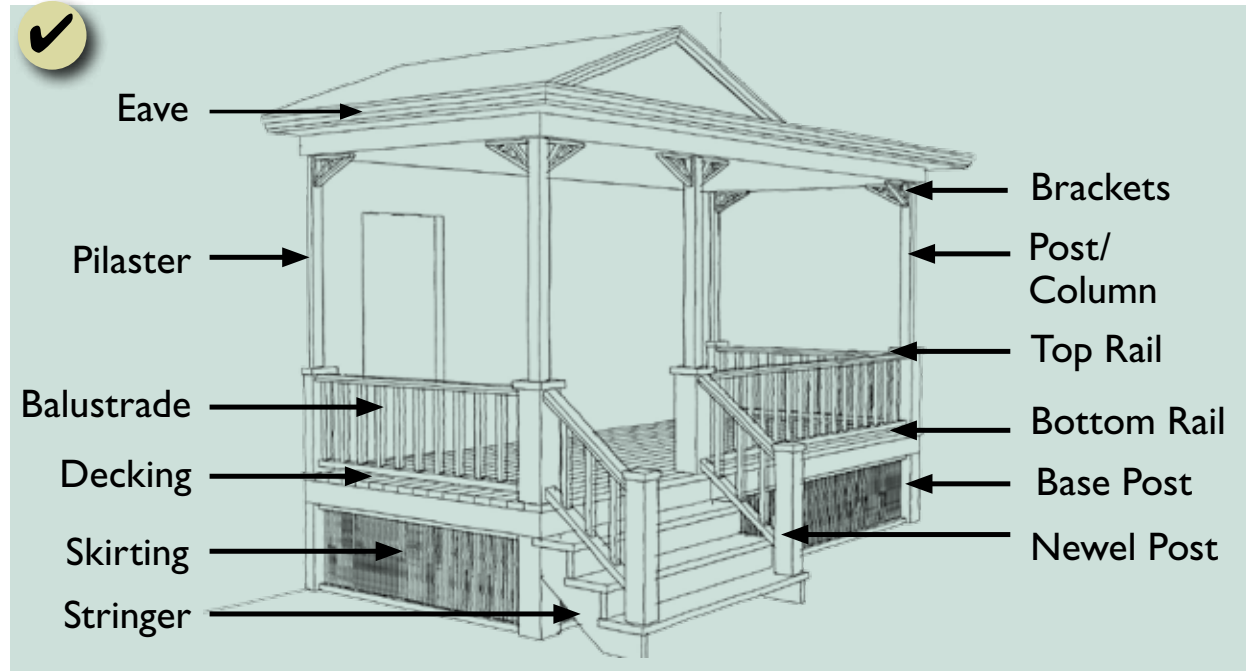

Figure 99: Typical porch features.



Figure 100: Preserve a porch in its original condition and form. A porch is one of the most important character-defining features of a façade.

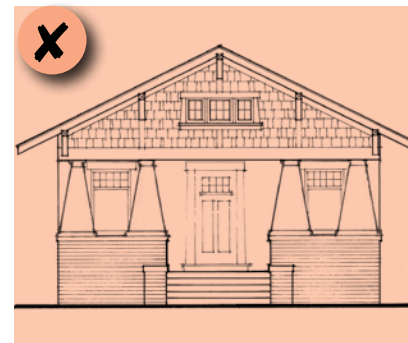

Figure 101: Design a replacement porch feature to relate to the overall scale of the primary structure. In this case the porch columns are excessively sized and therefore are inappropriate.



Figure 102: Preserve a porch in its original condition and form. A porch is one of the most important character-defining features of a façade.

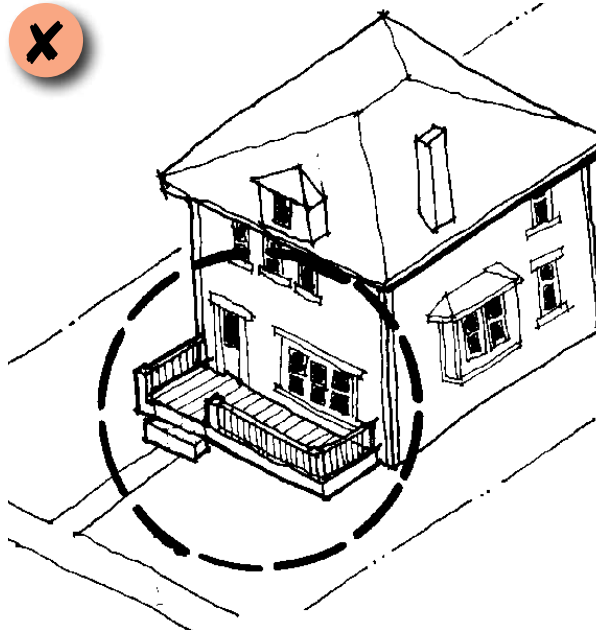

Figure 103: Locate decks and balconies on the rear elevation to respect the privacy of adjacent homes as well as the historic context and character of the property and the neighborhood.

3.23 When porch replacement is necessary, it shall be similar in character, design, scale and materials to those seen traditionally.

- › Design a replacement porch or stoop to be appropriate to relate to the overall scale of the primary structure.
- › Detailing a porch with non-tradition elements creates a false sense of history and is inappropriate.

3.24 Minimize the appearance of deck and balconies added to existing buildings.

- › Locate decks and balconies on the rear elevation to respect the privacy of adjacent homes as well as the historic context and character of the property and the neighborhood.
- › Balconies and decks should fit the style and character of the existing building.

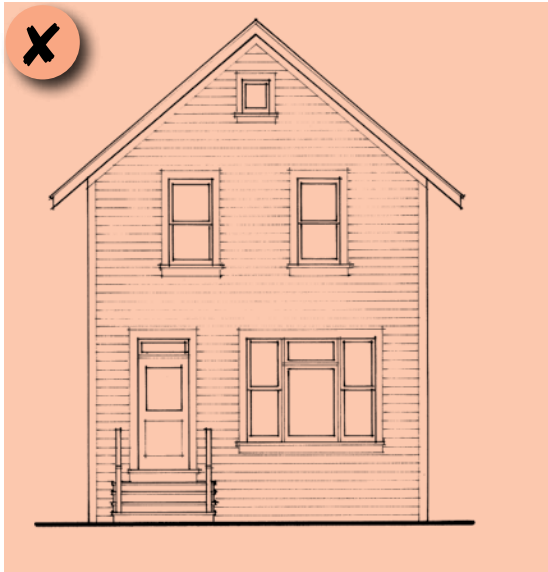

Figure 104: Existing Altered Condition: A vernacular style house with the original porch removed.



Figure 105: Preferred Approach, when historic documentation is available: A vernacular style house with a replacement porch designed similar to that seen historically.

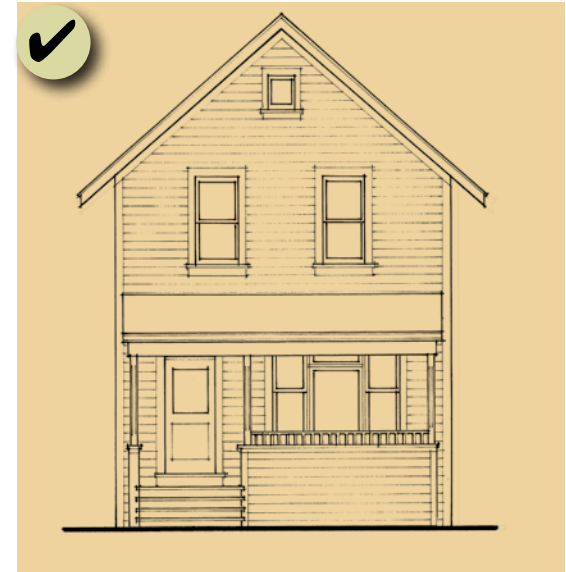

Figure 106: Acceptable Approach, when historic documentation is not available: A vernacular style house with a simplified interpretation of a traditional porch design.

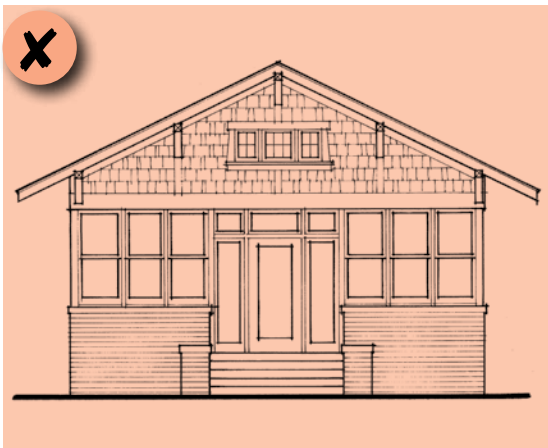

Figure 107: Existing Altered Condition: A vernacular style house with the original porch enclosed.

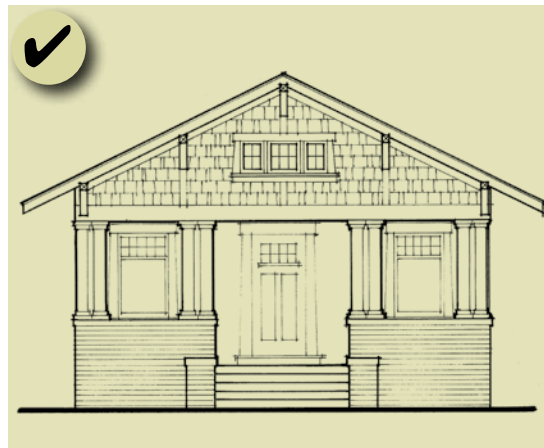

Figure 108: Preferred Approach, when historic documentation is available: A Craftsman style house with a replacement porch designed similar to that seen historically.

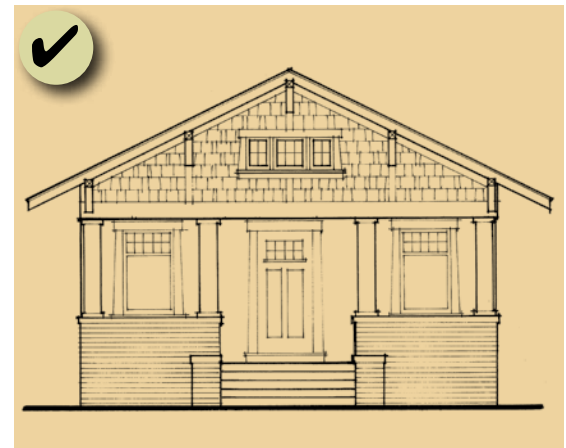

Figure 109: Acceptable Approach, when historic documentation is not available: A Craftsman style house with a simplified interpretation of a traditional porch design.



Figure 110: Clipped, side-gable roof form with loft dormer



Figure 111: Gable roof with dormers



Figure 112: Hip roof with boxed eave and brackets tops the primary form, and a hip roof tops the porch.



Figure 113: Gable roof with shallow eave over the primary form and a splayed gable roof form tops the one-story projecting entry feature.

HISTORIC ROOFS

Many roofs in the Old Town Neighborhoods are hip and gable roofs. These provide a visual continuity created by a pattern of similar roof forms along a block. The form, size, shape, pitch and materials of a historic roof help define the character of the building as it is perceived from the public way and should be preserved.

3.25 Preserve the form, materials and features of an original historic roof.

- › Maintain the perceived line and orientation of the roof as seen from the street.
- › Maintain roof overhangs because they contribute to the perception of the building's historic scale.
- › Preserve functional and decorative roof features, including original dormers, chimneys and eaves, especially when they are character-defining features of the structure.
- › Avoid altering the angle of a historic roof.
- › Do not cut back exposed roof rafters and soffits.

For More Information

See web link to *Preservation Brief 17: Architectural Character - Identifying the Visual Aspects of Historic Buildings as an Aid to Preserving Character*.

<http://www.nps.gov/tps/how-to-preserve/briefs/17-architectural-character.htm>

3.26 Repair original roof materials and features, and replace only when necessary.

- › Check roof flashing for open seams and look for breaks or holes in the roof surface.
- › Retain and repair roof detailing, including gutters and downspouts.
- › If replacement is necessary, use materials similar in color and texture to the original. Low profile asphalt shingles, for example, are appropriate replacements for wood shingles.

3.27 Minimize the visual impacts of rooftop alterations.

- › Do not visually overwhelm the original roof, particularly street-facing elevations, by altering the rooftop.
- › Do not remove or alter sizes of historic dormers on street-facing elevations.
- › Do not install a dormer or skylight on a front-facing roof plane.
- › Do not install a bubble skylight, or other form that does not have a low profile.

EXPOSED HISTORIC FOUNDATIONS

A historic building foundation contributes to the character of a historic structure and should be preserved.

Altering or replacing historic foundation walls is discouraged. However, it may be necessary to replace historic foundation walls with compatible new materials where the historic foundation is deteriorated beyond repair.

3.28 Maintain and repair a historic foundation.

- › Re-point historic masonry foundations to match the historic design.
- › Design landscaping and other site features to keep water from collecting near the foundation.
- › Do not cover a historic foundation with newer siding material.
- › Do not install windows, window wells or an access door on the front façade of a historic foundation.

3.29 Replace a foundation wall using new material that is similar in character to the historic foundation.

- › For example, if a stone foundation must be replaced, a material that conveys the scale and texture of the historic fabric may be considered.
- › Use materials and details that resemble those used in foundations on similar nearby historic properties.



Figure 114: Do not install a dormer or skylight on a front-facing roof plane.



Figure 115: Maintain and repair a historic foundation.



Figure 116: Re-point historic masonry foundations to match the historic design.

Two color paint scheme:



Figure 117: When designing a color scheme, consider the entire composition: The back plane of the main façade is a major surface for which a scheme should be devised. A color scheme for the front plane, composed of a porch in this case, should also be designed.

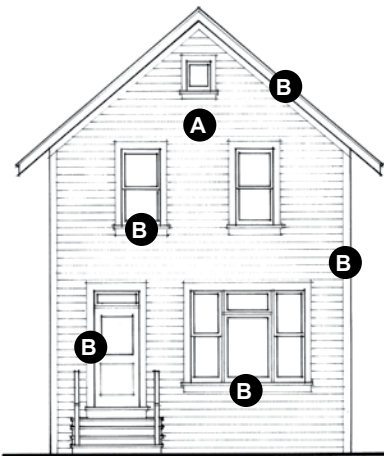

Figure 118: Apply a base color to the main plane of the façade (A). Apply a primary trim color to window and door frames, and edge boards (B).

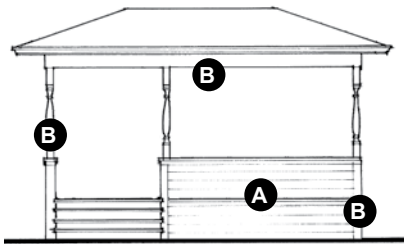

Figure 119: Apply a color to the front porch plane of the façade; if a solid porch wall is provided instead of balusters, this color should match the base color. For trim, columns, balusters and edge boards the trim color is typically the same color as the trim on the main building plane (B).

Maintenance Tips:

- › Look for breaks or holes in the roof surface and check the flashing for open seams.
- › Watch for vegetation, such as moss and grass, which indicates accumulated dirt and retained moisture.
- › Patch and replace areas with damaged roof material (often, repairing a roof can be much less expensive than complete replacement).

For More Information

See web link to *Preservation Brief 10: Exterior Paint Problems on Historic Woodwork*

<http://www.nps.gov/tps/how-to-preserve/briefs/10-paint-problems.htm>

PAINT

Historically, most wood surfaces on the exterior of a building were painted to protect them from weathering. Stucco structures also were sometimes painted.

3.30 Plan repainting carefully.

- › Seek professional advice and properly prepare surfaces before painting.
- › Do not paint unpainted masonry.
- › Do not use destructive paint removal methods such as various torches, sandblasting or water blasting which can irreversibly damage historic materials.

COLOR

Choosing the right combination of colors for a historic rehabilitation project can unify building elements with the façade and highlight important architectural detailing. Paint color selection should be appropriate to the architectural style and complement the building and its surroundings. Using the historic color scheme is an option, but new schemes that are compatible are also permitted.

3.31 Retain historic colors.

- › Retain the historic or early color and texture of masonry surfaces.

3.32 Use a color scheme that is compatible with the historic character of the structure.

- › Repaint with colors that relate to the period of historic significance of the building.
- › Use color schemes that are simple in character (generally one to three accent colors for trim elements).

ACCESSORY BUILDINGS AND CARRIAGE HOUSES

The Old Town Neighborhoods have alleys that provide automobile and service access to many of the residential properties. As a result, most accessory buildings and carriage houses are located to the rear of the property, along the alley. While buildings in the rear generally have little impact on the character of the street, they do contribute to the character of the alley context and should be preserved.

3.33 Preserve original accessory buildings and carriage houses when feasible.

- › Keep historic accessory buildings and carriage houses in good repair, similar to the primary building on the lot.
- › Avoid removing a historically-significant accessory building or carriage house.
- › When additional space is needed, consider constructing a modest addition, or adding another accessory building or carriage house (when allowed by code), rather than removing the historic one.
- › Preserve character-defining features of a historic accessory building and carriage house.

EXISTING ADDITIONS

Some existing additions may have become historically significant in their own right. Unless the building is being accurately restored to an earlier period of significance, additions that have taken on significance should be preserved. However, more recent additions may detract from the character of the building and could be considered for modification or removal.

3.34 Preserve an older addition that has achieved historic significance in its own right.

- › Respect character-defining building features of a historically-significant addition.
- › Do not demolish a historically-significant addition.

3.35 Consider removing an addition that is not historically significant.

- › Ensure that the historic fabric of the primary structure is not damaged when removing these features.



Figure 120: This one-and-a-half-story carriage house is oriented with the roof plane parallel to the alley. This building has been appropriately preserved.



Figure 121: Keep historic accessory buildings and carriage houses in good repair, similar to the primary building on the lot.



Figure 122: Accessory buildings have little impact on the character of the street; however, they do contribute to the character of the alley context and should be preserved.

Planning for Energy Efficiency

These standards address maintaining and improving resource and energy efficiency in a historic building, as well as methods for approaching energy conservation and generation technologies. The standards in this section apply to projects involving historic buildings. Other sustainability standards throughout this document will also apply.

Objectives for historic preservation and community sustainability are often in alignment. Follow these basic steps when considering a rehabilitation project for energy efficiency:

Step 1: Establish Project Goals.

Develop an overall strategy and project goals for energy efficiency to maximize the effectiveness of a project. This will establish a broad view that can help place individual actions into context. Focus on minimizing use of resources and energy, minimizing negative environmental impacts, and retaining the historic integrity of a property. Strategies should maximize the inherent value of the historic resource prior to considering alterations or retrofitting with new energy generation technology.

Step 2: Maintain Building Components in Sound Condition.

Maintaining existing building fabric reduces negative environmental impacts. Re-using a building preserves the energy and resources invested in its construction, and removes the need for producing new construction materials.

Step 3: Maximize Inherent Sustainable Qualities.

Typically, historic buildings in the Old Town Neighborhoods were built with resources and energy efficiency in mind. Construction methods focused on durability and maintenance, resulting in individual building features that can be repaired if damaged, thus minimizing the use of materials throughout the building's life cycle.

Buildings were also built to respond to local climate conditions, integrating passive and active strategies for year-round interior climate control, which increase energy efficiency. Passive strategies include building features such as roof overhangs and windows to provide both natural day lighting as well as management of solar heat gain. Active strategies typically include operable building features such as double-hung windows.

Identify a building's inherent sustainable features and operating systems and maintain them in good operating condition. In some cases these features may be covered, damaged or missing; repair or restore them where necessary.

Step 4: Enhance Building Performance.

A historic building's inherent energy efficiency should be augmented using techniques which improve energy efficiency without negatively impacting historic building elements. Noninvasive strategies such as increased insulation, weatherization improvements and landscaping should be employed.

Step 5: Add Energy-Generating Technologies Sensitively.





The flexibility of many historic buildings allows for the respectful integration of energy efficient technologies, i.e., solar panels and geo-thermal systems. Energy-generating technologies are the most commonly known strategies. However, the efficiency of a historic structure will often be great enough that generation technologies aren't the most practical solutions. Utilize strategies to reduce energy consumption prior to undertaking an energy generation project.

For More Information

See web link to *Preservation Brief 3: Improving Energy Efficiency in Historic Buildings*

<http://www.nps.gov/tps/how-to-preserve/briefs/3-improve-energy-efficiency.htm>

Historic Residential Building Energy Efficiency Strategy

- A Attic & Walls** 
 - › Insulate internally
- B Awnings & Porches**
 - › Restore porches and awnings
- C Doors** 
 - › Maintain original doors
 - › Weatherstrip
 - › Install a storm door
- D Roof Material**
 - › Retain & repair
- E Solar Panels**
 - › Set back from primary façade to minimize visibility from street
- F Chimney** 
 - › Install draft stopper
- G Windows** 
 - › Repair & retain original or early windows
 - › Retain original glass
 - › Enhance thermal & acoustic efficiency with storm windows (preferably interior)
 - › Weatherstrip

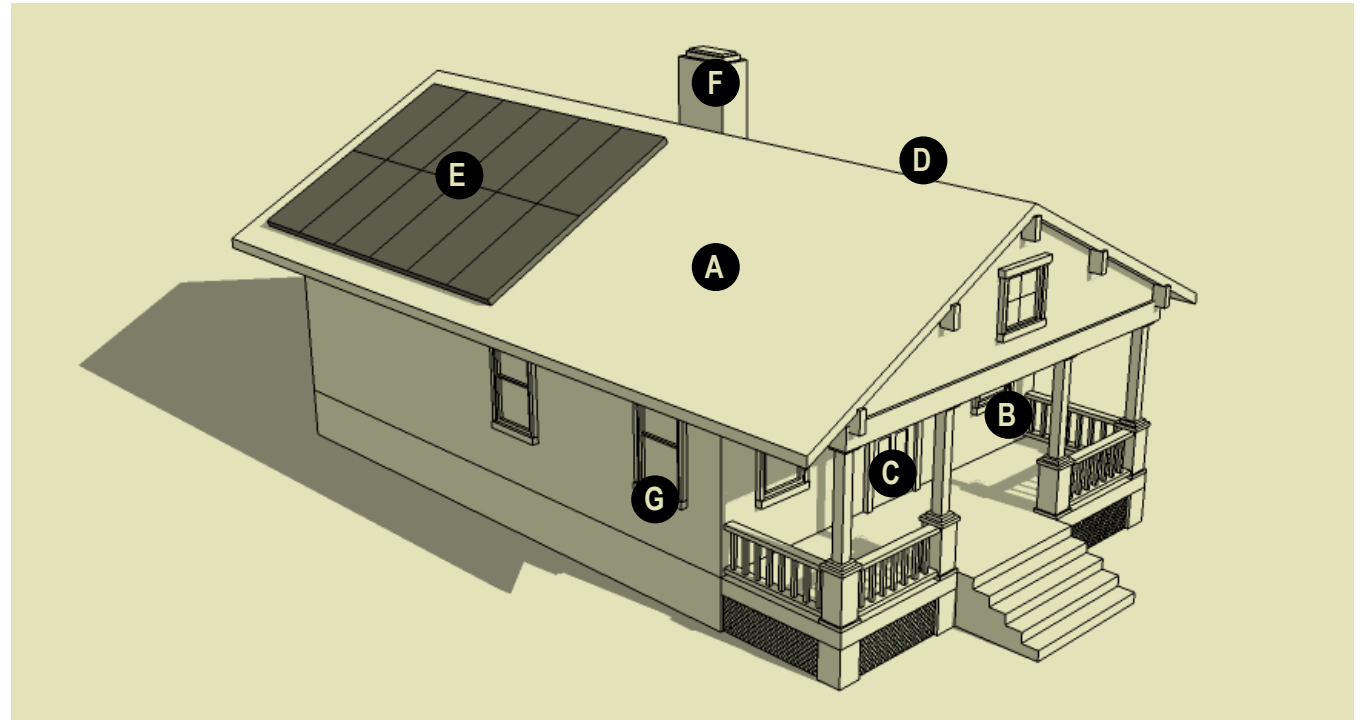

: Quick simple fixes that will increase the energy efficiency of a historic building.

Figure 123: This diagram summarizes a general strategy for energy conservation on a traditional residential building. These measures can enhance energy efficiency while retaining the integrity of the historic structure.



Figure 124: Consider using a storm window to enhance the energy efficiency of an existing historic window, rather than replacing it.

ENHANCING ENERGY PERFORMANCE

Improvements to enhance energy efficiency should complement the historic building. The structure, form and materials should be sensitively improved in energy efficiency terms to preserve the building's character.

3.36 Use noninvasive strategies when applying weatherization improvements.

- › Use cost-effective weather-stripping, insulation and storm windows to improve energy efficiency while preserving historic character.
- › Install additional insulation in an attic, basement or crawl space as a simple method to make a significant difference in a building's energy efficiency.
- › Provide sufficient ventilation to prevent moisture build-up in the wall cavity.
- › Install weatherization strategies in a way that does not alter or damage significant materials and their finishes.
- › Use materials which are environmentally friendly and that will not interact negatively with historic building materials.
- › Maintain historic windows; keep them in good repair and seal all leaks.
- › Use operable systems such as storm windows, insulated coverings, curtains and awnings to enhance performance of historic windows.
- › Use passive design strategies to increase the energy performance of the building, such as an appropriate eave depth that allows sun exposure in the winter and provides shade in the summer.

MAINTAINING ENERGY EFFICIENCY

The historic sustainable building features and systems of a historic building shall be maintained in good operating condition.

3.37 Preserve the inherent energy efficient features of the historic building in operable condition.

- › Identify a building's inherent sustainable features and operating systems and maintain them in good condition.

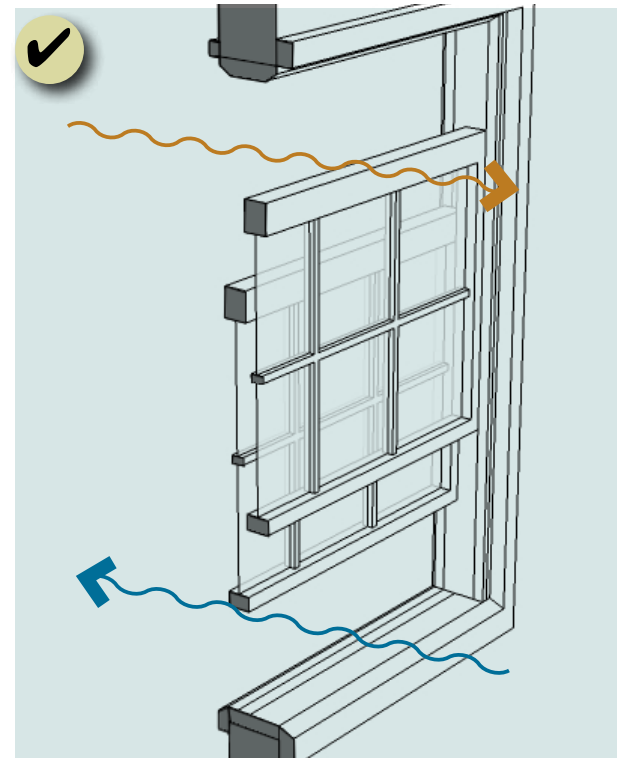

Figure 125: Double-hung windows found in many historic structures allow for transferring cool air in and warm air out during the summer months.

USING ENERGY GENERATING TECHNOLOGIES

Integrate modern energy technology into a historic structure while maintaining its historic integrity. Use of energy-generating technologies should be the final option considered in an efficiency rehabilitation project. Utilize strategies to reduce energy consumption prior to undertaking an energy generation project. Consider the overall project goals and energy strategies when determining if a specific technology is right for the project.

As new technologies are tried and tested, it is important that they leave no permanent negative impacts to historic structures. The reversibility (returning the building fabric to its historic condition) of their application is an important consideration.

3.38 Locate energy-generating technology to minimize impacts to the historic character of the site and structure.

- › Locate technology where it will not damage, obscure or cause removal of significant features or materials.
- › Maintain the historic character of the building.
- › Install technology in such a way that it can be readily removed and the historic character easily restored.
- › Use materials which are environmentally friendly and that will not interact negatively with historic building materials.

3.39 Install solar collectors to minimize potential adverse effects on the character of a historic property.

- › Place collectors to avoid obscuring significant features or adversely affecting the perception of the overall character of the property.
- › Size collector arrays to remain subordinate to the historic structure.
- › Install collectors on an addition or accessory building.
- › Minimize visual impacts by locating collectors back from the front façade on the primary building.
- › Ensure that exposed hardware, frames and piping have a matte finish, and are consistent with the color scheme of the primary structure.
- › Use the least invasive method to attach solar collectors to a historic roof.



Figure 126: Install collectors on an addition or accessory building.

Energy Audit

To inform an energy efficiency project strategy, conduct an energy audit. Energy audits can give a comprehensive view of how energy is currently managed, in the daily and seasonal cycles of use, and can also provide perspective on the payback of investment for potential work on the building. For example, an energy audit, when examined based on an overall strategy, may demonstrate that priorities shall be on increasing insulation in walls, ceilings and foundations, rather than replacing windows.

Locating Solar Panels on Historic Buildings

Existing Building

- » Gable facing street, side is south facing

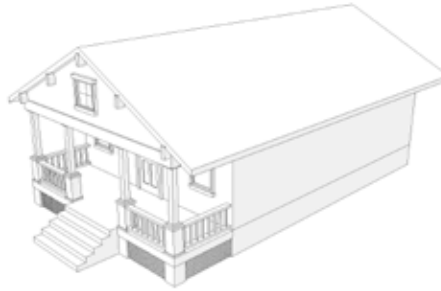

Preferred Location

- » Panels are set back from the front façade.
- » Panels are flush with the roof.

When should I use this approach?

- » The building is highly significant.
- » The context has many intact historic buildings.
- » The roof is highly visible.

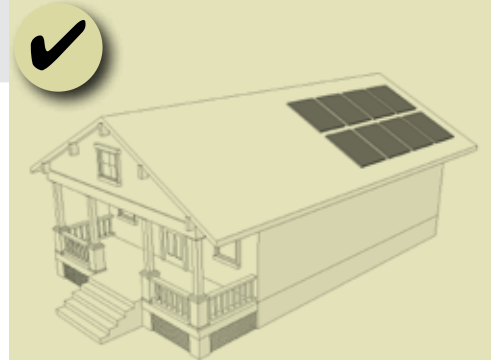

Acceptable Location

- » Panels are set back from the eave, but closer to the front façade.
- » Panels are flush with the roof.

When should I use this approach?

- » The building is a contributor to a district.
- » Site constraints restrict solar access.
- » The roof is not highly visible.

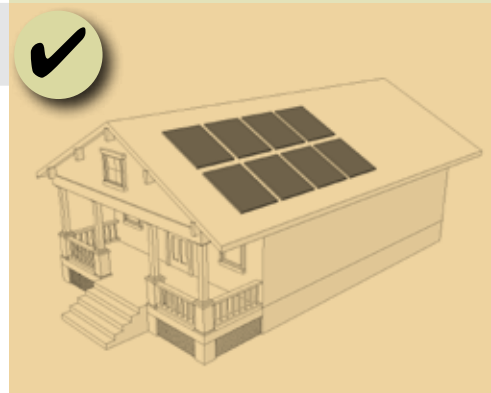

4

BUILDING DESIGN: GUIDELINES FOR NEW CONSTRUCTION

Building Design: Guidelines for New Construction

New construction helps the Old Town Fort Collins Neighborhoods remain a vital part of the changing city. As change occurs; however, it should help to reinforce the context of the character areas and historic districts.

This chapter provides design guidelines that promote new construction that is compatible with its historic context. It includes design guidelines for new residential buildings and accessory buildings. This chapter also includes design guidelines that address green buildings.

DESIGNING IN CONTEXT

The Old Town Neighborhoods are not frozen in time. They continue to evolve while maintaining their essential historic character. A new building in a historic context should be compatible with the surrounding historic fabric, but also express its true age. A key objective is to retain the overall character of the neighborhood while accommodating creative, yet compatible, new buildings. It is important to understand how new construction will affect the ability to perceive the historic sense of time and place. Ideally, a new building will contribute to an understanding of the area, or at least incorporate a neutral design that has little impact.

When designing a new building within a character area it is important to understand the hierarchy of context that influence the design. Each character area has unique design aspects that should be followed (See Chapter 2.) The surrounding context/block should determine design conditions such as setback, mass and scale. Adjacent properties define building features including materials, articulation, porches, windows and doors.

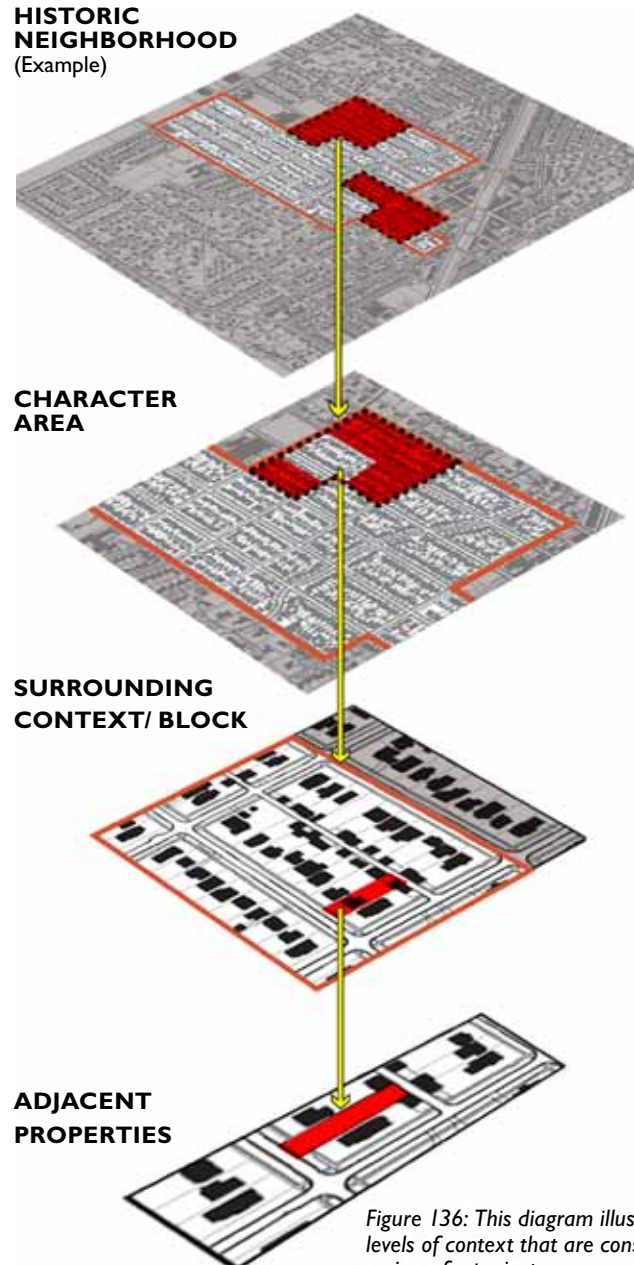

Figure 136: This diagram illustrates the levels of context that are considered in review of a project.



Figure 135: Design a building to be compatible with the context of the Old Town Neighborhood. Consider how the building will convey similar design attributes of a historic building and appear in scale, while expressing its true age.

Relationship to Zoning



The *Fort Collins Land Use Code* sets forth the fundamental requirements that apply to new construction throughout the city. New construction projects must also meet base standards for the applicable zone district. For the Old Town Neighborhoods, this includes the Neighborhood Conservation, Low Density (NCL) and the Neighborhood Conservation, Medium Density (NCM) zone districts. Design standards that apply include: minimum setbacks, maximum height, maximum floor area, maximum height and articulation, for example.

For More Information

Visit the Fort Collins Land Use Code to learn more about the requirements that apply to the zoning districts. https://www.municode.com/library/col/fort_collins/codes/land_use

Balancing the Design Variables with the Surrounding Historic Context

The design guidelines promote use of similar forms, materials and details to those used historically. However, this does not mean that total uniformity with the historic context is the objective. Rather, compatibility is achieved when a new building has a sufficient number of design variables which are similar in execution (but not necessarily identical) to typical design variables in the surrounding historic context. For example:

-  A new building with a form, height, roof, windows, materials and details that are identical to buildings in the surrounding historic context may be difficult to differentiate from its historic neighbors, and thus confuse the history of the neighborhood.
-  A new building with a form, height, roof and windows, or placement on the lot/setbacks, that are different from buildings in the surrounding historic context will contrast too much and impede interpretation of the historic context.
-  A new building with a similar form, height and roof, but that incorporates new (but similarly-proportioned and located) window designs and contemporary materials is more likely to achieve a successful balance between relating to design variables in the surrounding historic context and expressing its true age with simplified or contemporary features.

There are many other combinations of these variables that may be used to accommodate new, creative designs while also achieving compatibility with the historic context.

BUILDING DESIGN

Design a building to be compatible with the context of the Old Town Neighborhood. Consider how the building will convey similar design attributes of a historic building and appear in scale, while expressing its true age.

4.1 Design a new building to be recognized as current construction, while respecting key features of the character area as well as the surrounding block.

- › Use a simplified interpretation of historic designs found in the neighborhood, or use a contemporary design that is compatible with historic siting, massing and forms found in the neighborhood. At a minimum, an acceptable design should be neutral and not detract from the historic context.
- › Include features that relate to the surrounding block, such as front porches.
- › Use contemporary details, such as window moldings and door surrounds, to create interest and convey the period in which the structure was built.

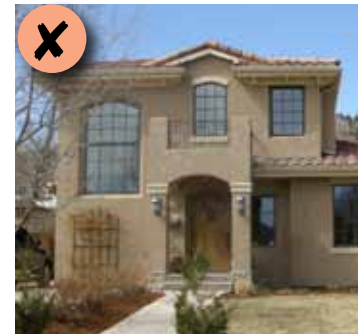

Figure 137: This building is not compatible with the Old Town Neighborhood. Its windows and entry features are out of proportion with others in the context. It is also too wide.



Figure 138: Design a building to be compatible with the context. A gable roof form and front porch are appropriate features; however, the porch should be raised similar to others in the context.



Figure 139: Design a building to be compatible with the context of the Old Town Neighborhood. Consider how the building will convey similar design attributes of a historic building and appear in scale, while expressing its true age.



Figure 140: Design a building to be compatible with the context. Providing a gable roof and one-story elements that step down to the street are appropriate features on this building.



Figure 141: This two-story building is compatible in several contexts. It has a similar roof form, window pattern and porch proportion to historic buildings in the neighborhood.

Impact Considerations for New Construction

Impact considerations address the visual and physical impacts of the new building on the integrity of the character area.

Some impact-related factors to consider include:

- » The impact on the abutting historic properties
 - Is one's ability to interpret the historic character of the abutting properties retained? (Especially in terms of perceiving their original mass, scale and relative prominence on the street or from other public vantage points?)
- » The impact on the block as a whole
 - Are the rhythm and alignment of buildings and their key features typical of the block retained?
 - Is the perception of the scale of structures along the block retained, as experienced at the street level?
 - If the character of an alley wall is also a key feature, is its scale also retained?

Overall Compatibility Considerations

To achieve compatibility, a new building should:

- » Relate to the character area design features, including setback and open space patterns, mass and form, entries and porches, materials and other features.
- » Relate to features in the surrounding historic context and on adjacent historic properties, including setbacks, foundation, porch and window heights, the proportions of windows and architectural features, as well as roof forms.
- » Express its true age, rather than directly imitating a historic style, or using faux historic treatments, to avoid confusing historic interpretation of the context.



Figure 142: This building has several compatible features such as the traditional massing, porch, articulation and materiality.



Figure 143: Design a building to be compatible with the context. A hip roof, simple building form and raised porch are appropriate features on this building. Porch and eave height are scaled appropriately.



Figure 144: New designs should relate to the fundamental characteristics of the historic houses on a block while also conveying the stylistic trends of today.



Figure 145: This building is not compatible with the Old Town Neighborhood context. The flat roof is inappropriate; however, the scale would be appropriate in several contexts.

BUILDING MASS AND SCALE

Each historic residential building exhibits distinct characteristics of mass, height and a degree of wall articulation that contributes to its sense of scale. As groupings, these buildings establish a definitive sense of scale. A new building or addition shall express these traditions of mass and scale, and it shall be compatible in height, mass and scale with its context.

4.2 Design a new residential building to incorporate heights and proportions that reference those on historic buildings in the surrounding context.

- › Design a new building to be within the range of lowest and tallest heights in the surrounding historic context.
- › Locate and proportion building features to reference similar features on historic buildings. For example, match window heights, door height, porch height, foundation height, floor-to-floor heights and other vertical proportions to those on nearby historic buildings.
- › Design a new façade to respect the proportions of height to width in the surrounding historic context.

One-and-a-half story building steps down to one story

The massing of this new infill building is compatible with the existing context. It reflects similar form, height, wall lengths and massing as historic buildings in the context.

Note the simple primary and secondary volumes; the secondary volume appropriately steps down to the back yard.

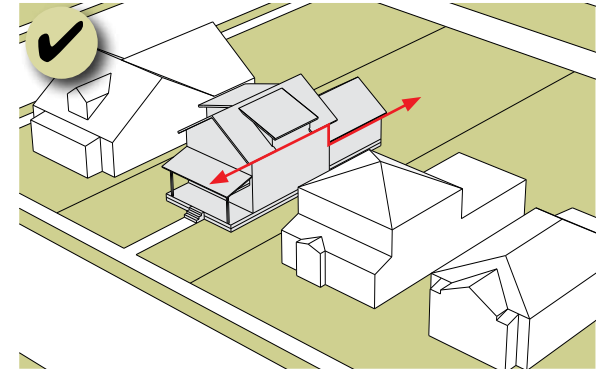

Two-story building with wall offset to one-and-a-half story

The massing of this new infill building is compatible with the existing one and two story context. It reflects similar form, height, wall lengths and massing as historic buildings in the context.

Note the simple primary and secondary volumes; the secondary volume appropriately steps down to the back yard.

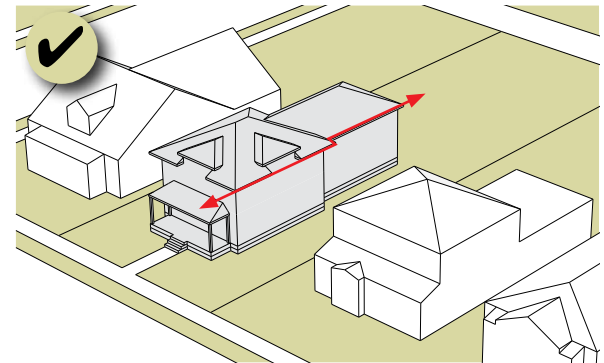

One-and-a-half story building steps up to two-story

The massing of this new infill building is compatible with the existing context. It reflects similar form, height, wall lengths and massing as historic buildings in the context.

Note this building form is comprised of a central primary mass with secondary volumes stepping down to the street and back yard. This is an appropriate form for many one and two story contexts.

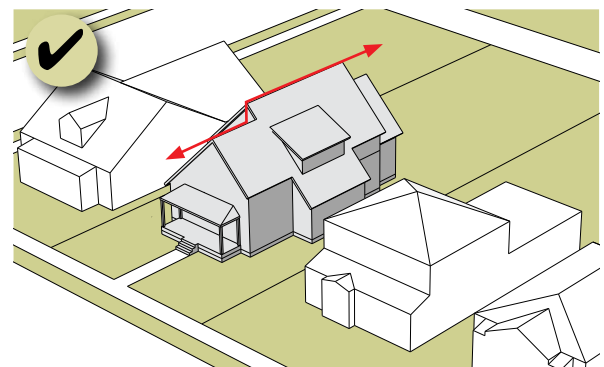



Figure 146: Avoid using “boxy” building forms when they are not typical of the surrounding historic context.



Figure 147: Use simple building and roof forms that appear similar to historic buildings in the surrounding context. This form is appropriate in a majority of the contexts.



Figure 148: Use façade articulation techniques to help a building fit within the scale of the surrounding historic context.



Figure 149: Use façade articulation techniques to help a building fit within the scale of the surrounding historic context.

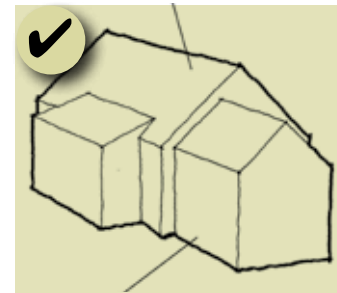

Figure 150: Subdivide the mass of a larger building into a simple primary volume with additional secondary volumes, similar to historic buildings in the surrounding context.

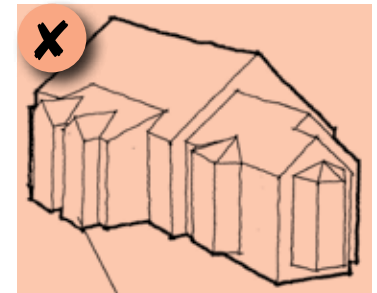

Figure 151: Avoid “busy and complex” building forms.

4.3 Use residential building forms that are compatible with the mass and scale of surrounding historic buildings.

- › Use simple building and roof forms that appear similar to historic buildings in the surrounding context.
- › Avoid “busy and complex” building forms.
- › Subdivide the mass of a larger building into a simple primary volume with additional secondary volumes, similar to historic buildings in the surrounding context.
- › For buildings with more than two units, define individual units in modules that express typical historic dimensions.
- › Avoid using boxy building forms when they are not typical of the surrounding historic context.

BUILDING ARTICULATION

Providing articulation in the building mass will minimize impacts on the neighborhood context and neighboring buildings. For example, creating offsets in long walls and stepping down height on all building facades are good design choices.

4.4 Use façade articulation techniques to help a building fit within the scale of the surrounding historic context.

- › Use vertical and horizontal wall offsets (changes in the wall plane) to reduce the overall scale of a building as viewed from the street.
- › Use vertical and horizontal wall offsets to reduce the visual impact of long side wall areas on neighboring properties and the street.



Figure 154: This building wall is inappropriate; it is too long and does not have any wall offsets.



Figure 152: Use façade articulation techniques to help a building fit within the scale of the surrounding historic context.



Figure 153: Use façade articulation techniques to help a building fit within the scale of the surrounding historic context. This contemporary building applies appropriate vertical and horizontal articulation techniques along the front and side wall planes.

One-and-a-half story building with vertical and horizontal articulation

This new one-and-a-half story building reflects a similar mass and scale to historic building forms located in the neighborhood. To help break up the mass the wall plane is offset and the height steps down to a one-story mass. There is also some modest articulation at the dormer that breaks up the roof plane.

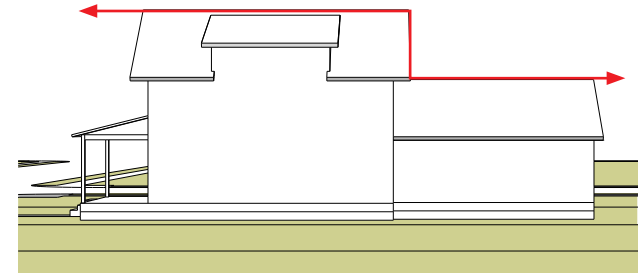
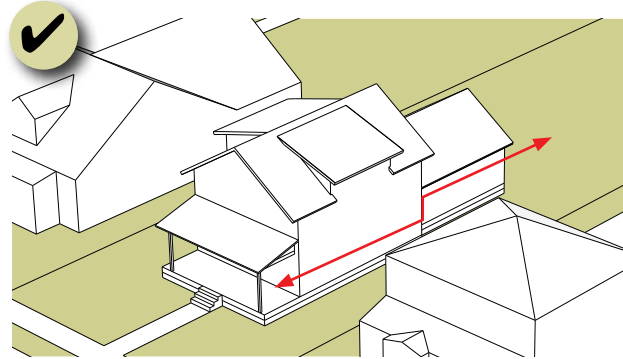

One-and-a-half story building with vertical and horizontal articulation

This new one-and-a-half story building reflects a similar mass and scale to historic building forms located in the neighborhood. To help break up the mass the wall plane is offset and the height steps down at the midpoint of the building mass.

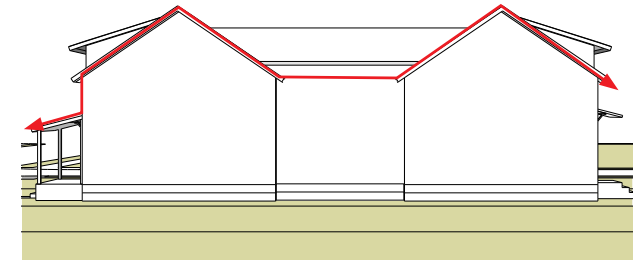
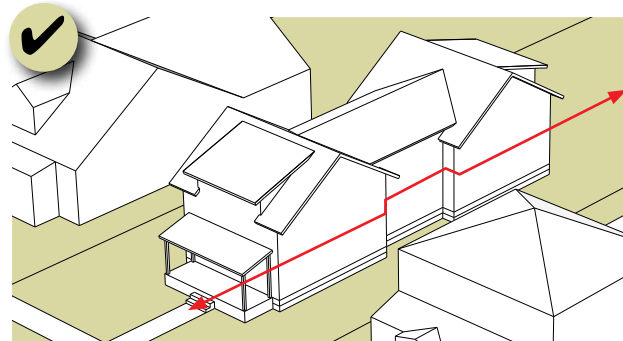

Two-story with vertical and horizontal articulation

This new two-story building reflects a similar mass and scale to historic building forms located in the neighborhood. To help break up the mass the wall plane is offset and a one-and-a-half story building mass projects from the front wall plane and a one-story mass projects from the rear wall plane.

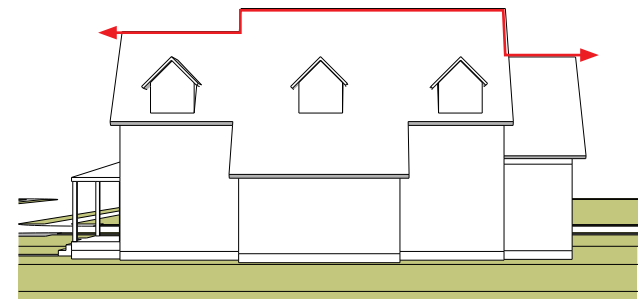
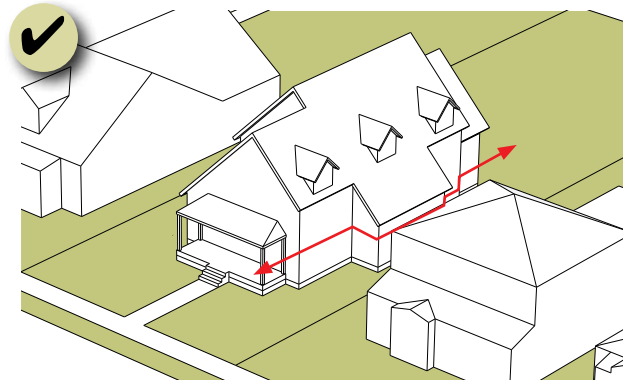

PORCHES, ENTRY FEATURES, BALCONIES AND DECKS

Entries, including porches and stoops, are important character-defining features. When oriented to the street, a front entry helps to establish a connection with the neighborhood and a sense of scale at the building front. An entry should be designed to be in scale with the building and compatible with the context.

Decks and balconies on residential buildings weren't traditionally found in the Old Town Neighborhoods. In recent years, however, they have become an amenity enjoyed by some residents. Decks and balconies can provide additional opportunities for outdoor living space. As these types of outdoor improvements are introduced, property owners should minimize impacts to the historic context, historic buildings and privacy of neighboring residents.

4.5 Use a front porch to provide a visual and functional connection between the building and the street.

- › Use a front porch to define the entry.
- › Orient a front porch towards the street and sidewalk.

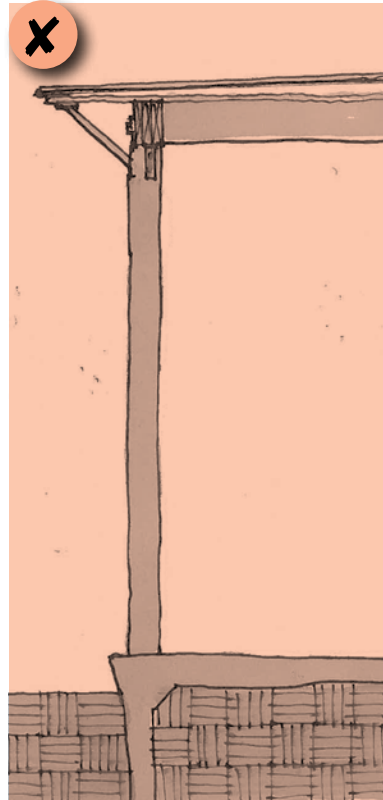

Figure 155: Character-defining features of a historic porch include height alignment along the street, balustrades and column to roof proportions. The proportions in this contemporary porch are inappropriate for most contexts with historic front porches since the porch is too tall, the porch floor is too close to grade and a balustrade is not provided.

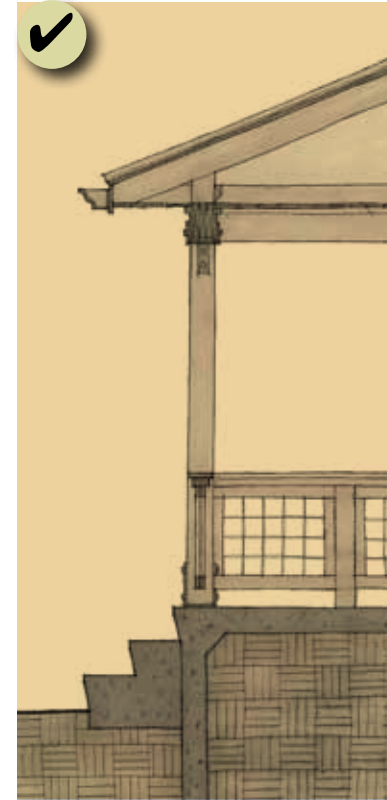

Figure 156: Use similar porch components to those seen historically with some contemporary interpretation.

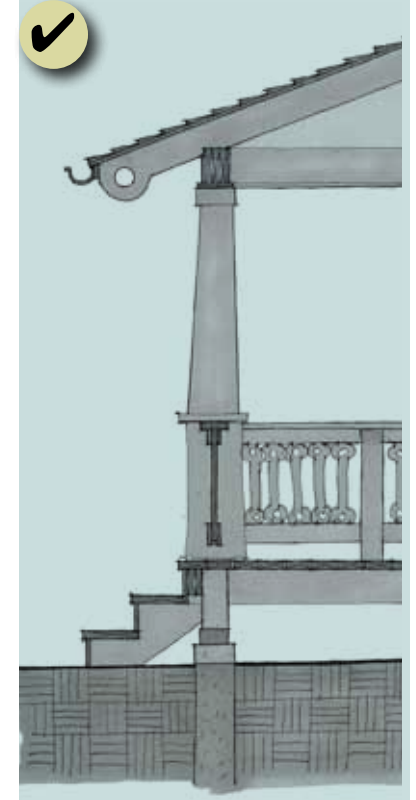

Figure 157: Proportion a front porch and its key features to be compatible in size, height and scale with the building and surrounding historic context.



Figure 158: A small balcony may be appropriate on the front of a new building if it is modest in size and incorporated into a gable end or porch roof.

4.6 Design a porch to be compatible with the historic context.

- › Proportion a front porch and its key features to be compatible in size, height and scale with the building and surrounding historic context.
- › Locate a front porch in alignment to those seen in the neighboring context.
- › Using materials and detailing similar to those seen historically with some contemporary interpretation is appropriate. Wood balustrades and porch posts were common on many styles.

4.7 Minimize the appearance of an outdoor balconies and decks.

- › Locate decks to the rear of the property to respect the historic context.
- › A small balcony may be appropriate on the front of a new building if it is modest in size and incorporated into a gable end or porch roof.



Figure 159: Use a front porch to provide a visual and functional connection between the building and the street.



Figure 160: Use a front porch to define the entry. This porch uses traditional detailing; however, providing a contemporary balustrade would be more appropriate.



Figure 161: Simple detailing of a porch on a new Vernacular building appropriately displays the building's age and stylistic influence.



Figure 162: This porch is not in proportion with the historic context since the porch columns are oversized.



Figure 163: Orient a front porch towards the street and sidewalk.



Figure 164: The addition of a trellis on a simple vernacular building at the porch stoop is appropriate.



Figure 165: Use window and door widths, heights and materials that are similar to doors on historic buildings in the surrounding historic context.

DOORS AND WINDOWS

Windows and doors are important character-defining features of buildings in the Old Town Neighborhoods. They provide a sense of scale and visual interest to the composition of a facade. They should be designed to be compatible with the surrounding context and their materials should be durable.

4.8 Design windows, doors and other features to be compatible with the historic context.

- › Incorporate windows, doors and other openings at a ratio similar to those found on nearby historic buildings, especially those with public visibility.
- › When using contemporary window patterns and designs, ensure they respect the character, alignments and proportions of windows in the surrounding historic context.
- › Use window and door widths, heights and materials that are similar to doors on historic buildings in the surrounding historic context.
- › Use simplified configurations of historic doors rather than replicating a historic door exactly.
- › Use clear or near clear low-e glass in windows.
- › Set back a window or door from the outside wall plane so a reveal is evident, resulting in a shadow line around the opening. The window or door should not appear flush with the outside wall plane.



Figure 166: Design windows, doors and other features to be compatible with the historic context.



Figure 167: When using contemporary window patterns and designs, ensure they respect the character, alignments and proportions of windows in the surrounding historic context.

4.9 Use durable window materials.

- › Permitted window materials include metal and wood frame.
- › Inappropriate window materials include synthetic materials that do not have a proven durability, such as plastic snap-in muntins.



Figure 168: Design windows, doors and other features to be compatible with the historic context. This can be achieved by using window and door sizes similar to those found on historic buildings. The pattern of window and door styles shown here illustrate appropriate proportions.



Figure 169: Set back a window or door from the outside wall plane so a reveal is evident, resulting in a shadow line around the opening. The window or door should not appear flush with the outside wall plane.



Figure 170: A window should not appear flush with the outside wall plane.



Figure 171: The combination of brick and wood material is appropriate; brick is typically the base material and wood is used as an accent.



Figure 172: Wood siding is an appropriate material. Note this addition uses a narrow wood lap to differentiate it from the existing building.



Figure 173: The combination of stucco and wood material is appropriate. In this example stucco is the base material with a wood accent in the gable. The reverse is also appropriate.



Figure 174: This combination of horizontal and vertical wood siding is an appropriate application. Note how the vertical boards highlight the gable end in a unique design approach.



New Addition **Historic Building**

The wood lap siding material on the new addition complements the masonry in the following ways: it is a subordinate material, the brick joints and siding width are similar scale, and the use of color is also complementary.

MATERIALS

Historic primary building materials in the neighborhood include masonry (mostly brick), wood lap siding and board and batten siding. Metal and asphalt are used as roofing materials. There is also some use of stone, mostly at the foundation. Today, these materials are key to the character of the neighborhood.

New building material should reflect the range of textures, modularity and finish of those employed historically. They also should contribute to the visual continuity of the area. They should be durable in their application.

4.10 Use building materials that appear similar in scale, color, texture and/or finish to those seen historically in the context.

- › Use materials that are proven to be durable in the local climate. For example, all wood siding should have a weather-protective finish.
- › Use historic materials, including wood and brick. Stucco may also be considered; however, it should be applied in a similar manner as it was historically, employing a similar texture and finish.
- › Use masonry with a modular dimension similar to typical masonry materials.
- › Imitation or synthetic materials, such as aluminium or vinyl siding, imitation brick or stone and plastic are inappropriate.

EXTERIOR SIDING

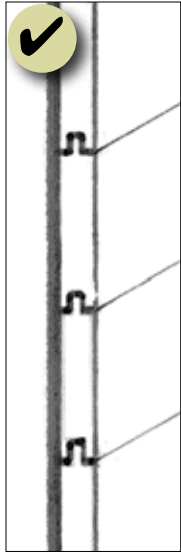

Tongue & Groove

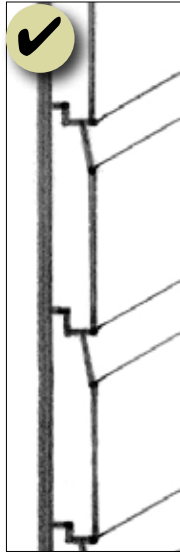

Ship Lap



Clapboard

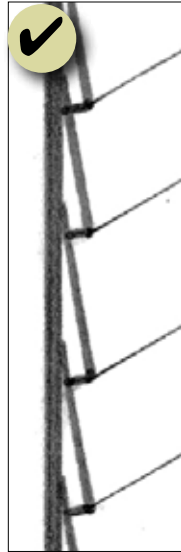

Beveled

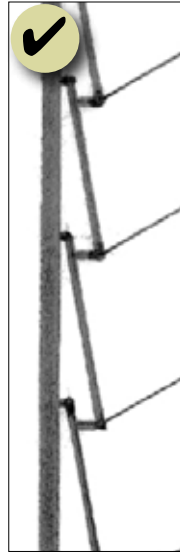

Rabbeted

MASONRY JOINTS

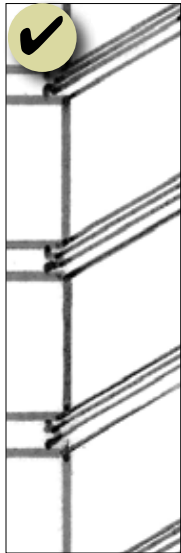

Beaded

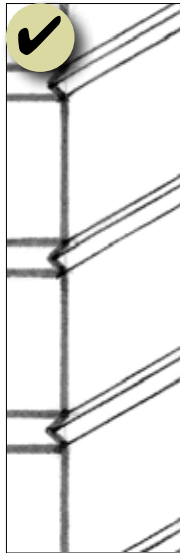

V-Shaped

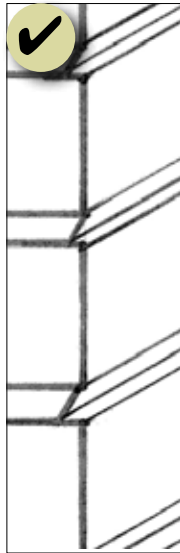

Struck

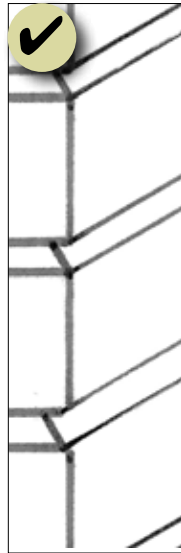

Weathered

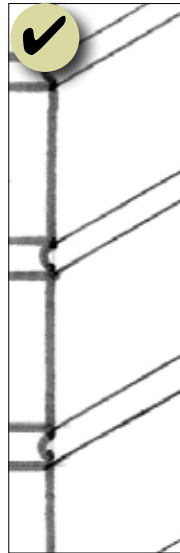

Concave

SHINGLE PATTERNS

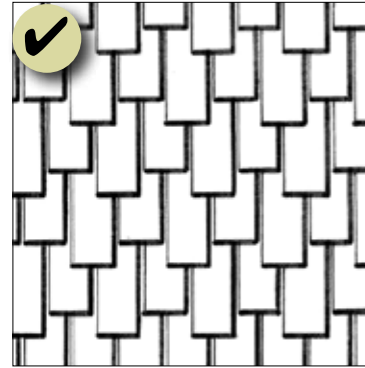

Staggered

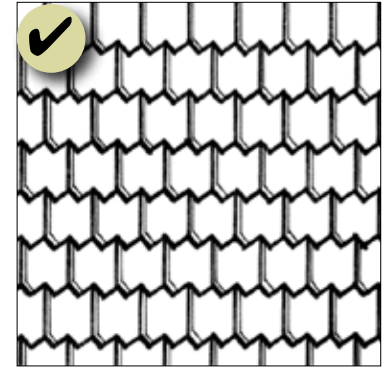

Sawtooth

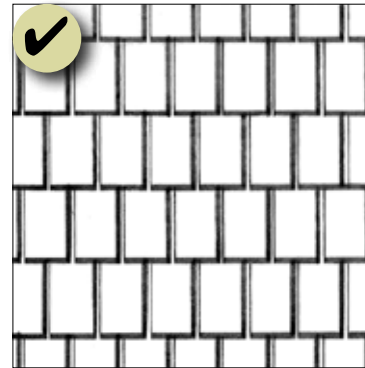

Coursed

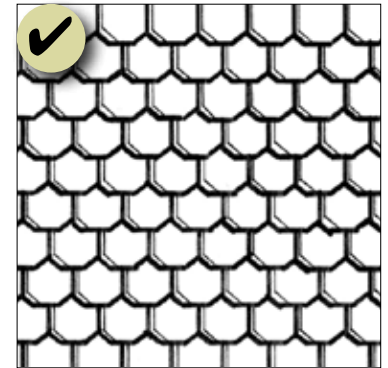

Fish Scale

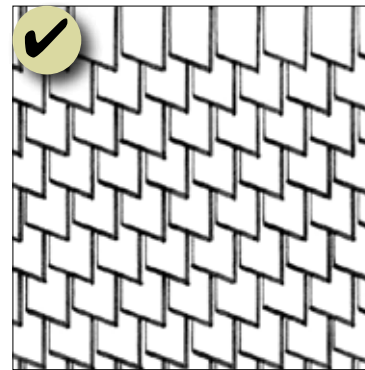

Chisel

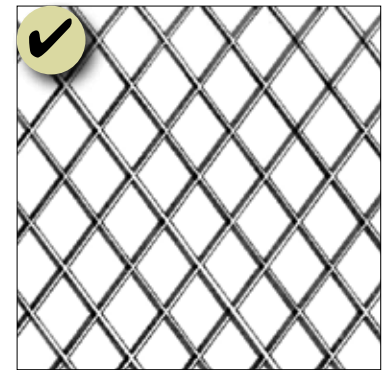

Diamond



Figure 175: This eave is inappropriate since it does not provide an overhang.



Figure 176: Provide overhanging roof eaves that appear similar in scale to those seen historically in the context.

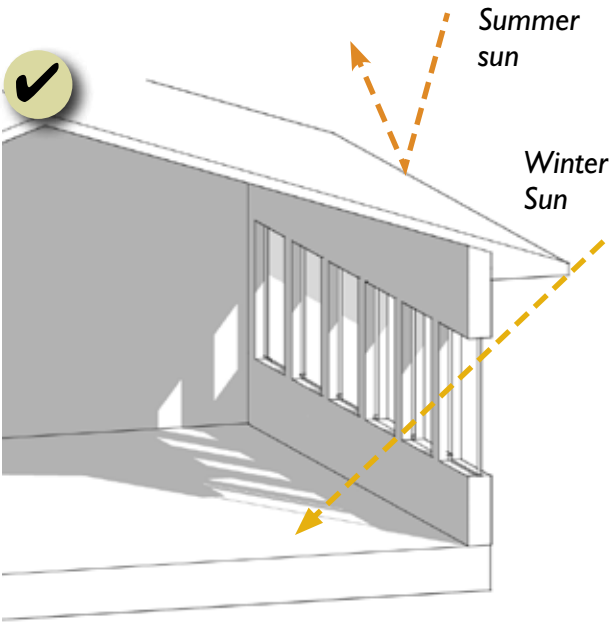

Figure 177: An eave overhang protects the wall material and also assists in cooling the building in the summer.



Figure 178: Boxed eaves with generous overhangs are appropriate.

EAVES

Eaves are historic features of a historic roof. Their design often varies with the building style; however, they mostly have a generous overhang. The overhang protects the wall material and also assists in cooling the building in the summer. This feature is important to the neighborhood context and should be incorporated in the roof design.

4.11 Provide overhanging roof eaves that appear similar in scale to those seen historically in the context.

- › Boxed eaves, exposed and enclosed rafters are appropriate eave configurations.

General Design Guidelines for Additions to Historic Buildings

This section provides guidelines for designing compatible additions to historic buildings. The General Design Guidelines for New Construction on the previous pages also apply to new additions.

Impact Considerations for Additions

Impact considerations address the visual and physical impacts of the addition on the integrity of the property, and one's ability to perceive its historic character, as well as that of its context.

Some impact-related factors to consider include:

- » The impact on the historic building
 - Is the addition visible?
 - Does the addition remain visually subordinate to the historic building?
 - Is one's ability to interpret the historic character retained? (Especially in terms of perceiving the original mass, scale and prominence of the property)
 - Are alterations to key character-defining features avoided or at least minimized?
 - Is the structural integrity of the property retained, or even improved?
- » The impact on the abutting historic properties
 - Is one's ability to interpret the historic character of the abutting properties retained? (Especially in terms of perceiving their original mass, scale and relative prominence on the street or from other public vantage points?)

Design Variables for an Addition

Design variables include basic scale and proportion considerations that relate to the compatibility of the addition with the primary building and surrounding historic context.

Design variables to consider include:

- » The height of the addition

Keeping floor heights in the range of those on the historic building, or even lower, may help keep an addition visually subordinate to the historic building.

- » The degree of setback

Does the original primary façade (front) remain visually prominent? An addition should be set back from the façade and other key walls that contribute to the character of the property. The setback should be a sufficient distance such that the historic building remains prominent.

- » Simplicity of design

Is the design of the addition subordinate in character? The design should be relatively simple in architectural character and detailing, such that it does not call undue attention to itself. The historic building should remain the prominent feature, when feasible.

60s Style Ranch and One-and-a-Half Story Addition

This rear addition is taller than the original building but is still clearly differentiated with a connecting element and complementary roof form on the dormer to achieve an acceptable level of compatibility with the historic building and context.

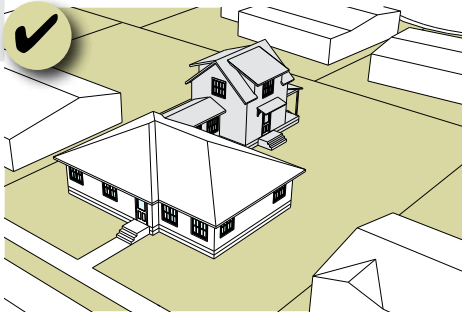

60s Style Ranch and One-Story Addition

This rear addition is similar in height and form to that of the original building and is compatible with the historic building and context.

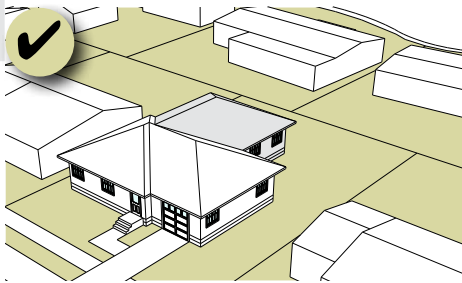

60s Style Ranch and One-Story Additions

These modest additions step down in height to the side and rear yard, and achieve an acceptable level of compatibility with the historic building and context.

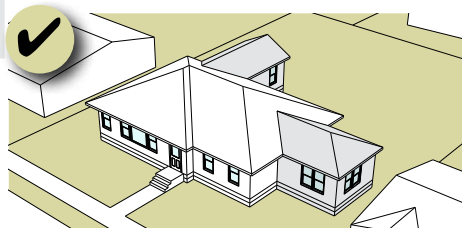

Classic Cottage with Small Addition

This modest rear addition steps down in height to that of the original building, and achieves an exceptional level of compatibility with the historic building and context.

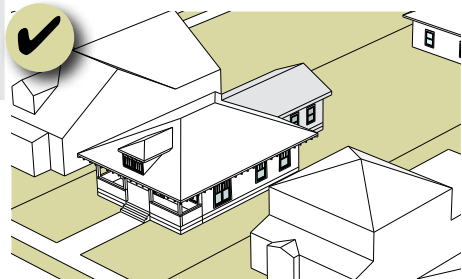

ADDITIONS

For many properties, an addition to the rear or side of the historic building is the best approach to gain additional living area. A compatible addition maintains the general appearance of a historic building especially from key public vantage points, minimizes damage to the original building by preserving character-defining features and ensures the addition relates to the fundamental characteristics of the block while also appearing as new construction.

4.12 Locate an addition to be subordinate to the original structure.

- › Place an addition to the rear of the original structure whenever possible.
- › Design an addition to have minimal visual impact to the existing structure.
- › Consider a compatible side addition if a rear addition is not possible.

4.13 Locate an addition to retain open space patterns.

- › Retain original open space at the sides and rear of the structure.
- › Avoid the excessive loss of existing open space with a large addition.

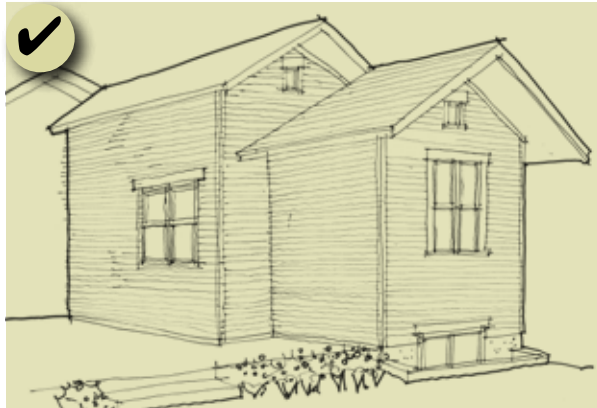

Figure 179: Consider locating additional square footage to the rear and below grade as illustrated in this sketch.

4.14 Design an addition to a historic building to respect the character-defining features of the surrounding historic context, and the original primary structure.

- › Design an addition to be compatible with the scale, massing and rhythm of the historic building and context.
- › Align porch eaves, roof lines and other features with adjacent structures, when possible.
- › Use materials that complement the color and scale of the historic materials along the street.
- › Design windows and doors to be compatible with the primary structure and surrounding historic context, particularly when visible from public vantage points.
- › Consider locating additional square footage to the rear and below grade.

Classic Cottage and One-and-a-Half Story Addition with Accessory Building

This rear addition is taller than the original building but is still clearly differentiated with a connecting element to achieve an acceptable level of compatibility with the historic building and context.

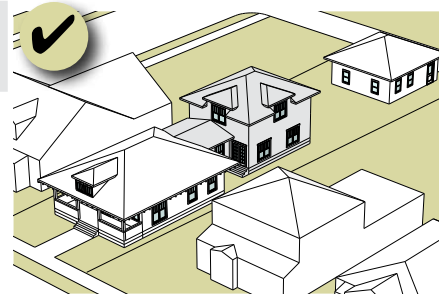

L-Shaped Building and One-and-a-Half Story Addition

This rear addition is similar in height to that of the original building, but is still clearly differentiated with a connecting element to achieve an acceptable level of compatibility with the historic building and context.

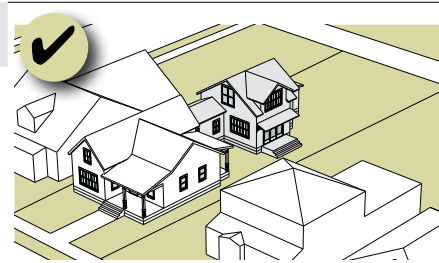

L-Shaped Building with Modest Addition

This modest rear addition steps down in height to that of the original building, and achieves an exceptional level of compatibility with the historic building and context.

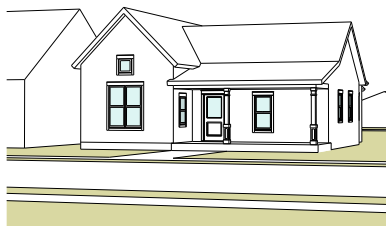
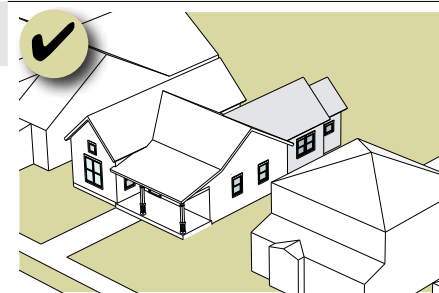

Four Square and Two-Story Addition plus Carriage House

This Carriage House addition is located along the alley and achieves an exceptional level of compatibility with the historic building and context.

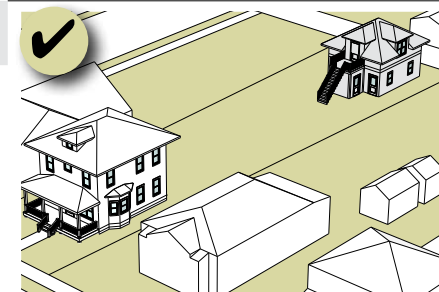



Figure 180: This addition steps down from the historic building, is a contemporary design, uses complementary materials and is a subordinate mass.



Figure 181: Differentiate an addition from the original structure with an offset and change in material.



Figure 182: Use simplified version of building components and details found in the surrounding historic context on additions, such as the arched windows and deck detailing on this addition.

4.15 Design an addition to be recognized as current construction.

- › Do not design an addition to be an exact copy of the existing style or imply an earlier period or more ornate style than that of the original structure.
- › Differentiate an addition from the original structure with an offset, change in material and/or connector.
- › Use simplified versions of building components and details found in the surrounding historic context. These may include:
 - Window, moldings or other features
 - Porches



Figure 183: Differentiate an addition from the original structure with an offset and change in material.



Figure 184: Design an addition to be recognized as current construction.

4.16 Design a dormer addition to minimize impacts on the building.

- › A new dormer on a historic building should be visually subordinate to the overall roof mass and should be in scale with those on similar building styles.
- › Locate a new dormer to the rear and/or the side (set back from the front facade) to help preserve the existing roof form and historic building materials. Also, the dormer should be located below the ridge line.
- › When a new dormer is visible from the public way the roof form should complement the character of the primary roof form.
- › The number and size of dormers should not visually overwhelm the scale of the primary structure.
- › Minimize the height of a dormer addition to ensure the historic structure remains visually prominent.
- › Do not obscure, cover or remove historic features when adding a dormer.



Figure 185: Locate a new dormer to the rear and/or the side (set back from the front facade) to help preserve the existing roof form and historic building materials. Also, the dormer should be located below the ridge line.

One-story connector to one-story addition

The subordinate connector provides a compatible transition to the new one story addition. The height of the connector steps down and the wall plane is offset from the historic building.

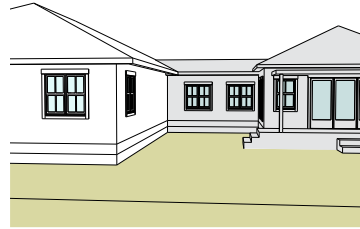
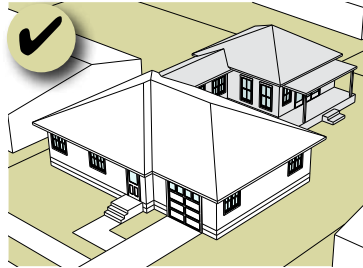

One-story connector to one-and-a-half story addition

The subordinate connector provides a compatible transition to the new one-and-a-half story addition. The height of the connector steps down and the wall plane is offset from the historic building.

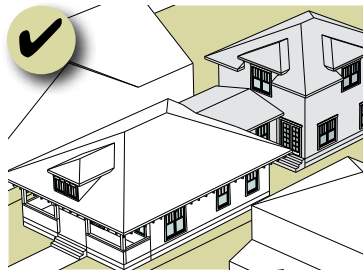

CONNECTORS

Additions to historic residential buildings should respect the existing building characteristics of mass, height and form. One approach to transition a new addition to a historic building is to use a connector. A connector can provide a compatible transition that retains the integrity of the historic building.

4.17 Consider incorporating a compatible connector between a historic building and new addition.

- › Use a one story or one-and-a-half story connector. Stepping the height down from the historic building is preferred.
- › Position the connector where it will have the least impact on the historic fabric of the existing building, typically at the rear of the building.
- › Use compatible mass, scale, materials, and windows and doors.

Accessory Buildings and Carriage Houses

ACCESSORY BUILDINGS AND CARRIAGE HOUSES

Accessory buildings and carriage houses are historically subordinate in scale and character to the primary building and are typically located to the rear of the lot. Accessory buildings are primarily used for storage and parking, while carriage houses provide a living unit with or without storage and parking. While these buildings in the rear generally have little impact on the character of the street, they do have an impact on the character of the alley and the neighbors to the rear. This character should be maintained.

4.18 Locate an accessory building and carriage houses to reinforce surrounding historic development patterns.

- › Locate a new accessory building and/or carriage house similar to the range of locations in the surrounding context. This is typically to the rear of the primary building and along an alley (where they exist).
- › On a corner lot, set back a new accessory building and/or carriage house from the side street to minimize impacts on the historic streetscape.
- › Avoid making new curb cuts for driveways when that is not part of the historic pattern along the block.

One-and-a-half-story accessory building accessed from the street

In some character areas of the neighborhood the accessory buildings are accessed from the street (e.g., in recent past neighborhood).

The new accessory building is compatible with the primary building on the lot since it has a subordinate mass and is set back to the rear.

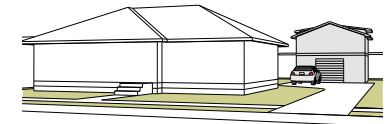
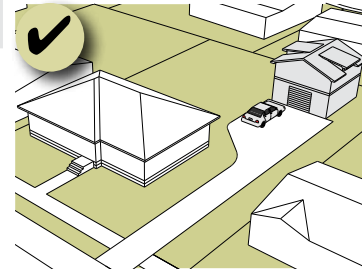

One-story accessory building accessed from the street

In some character areas of the neighborhood the accessory buildings are accessed from the street (e.g., on the narrow end of the lots where an alley is not present).

The new accessory building is compatible with the primary building on the lot since it has a subordinate mass and scale and similar roof form.

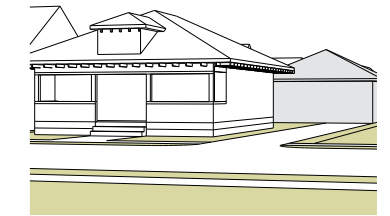
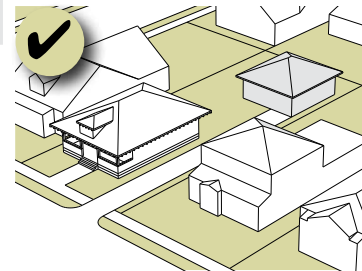

One-story accessory building accessed from the alley

In most character areas an accessory building is accessed from the alley.

The new accessory building is compatible with the primary building on the lot since it has a subordinate mass and scale and similar roof form.

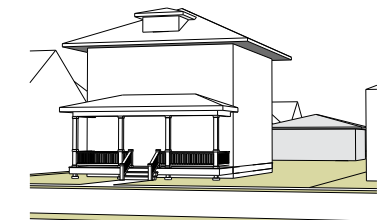
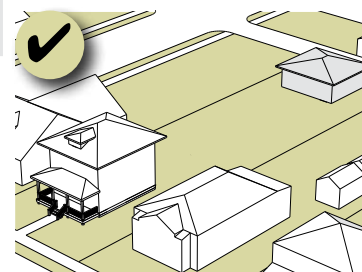



Figure 186: Design the mass, form and roof shape of a new accessory building to be compatible with the primary building and surrounding historic context.



Figure 187: Use materials that are of a similar color, texture and scale to materials of the primary building.



Figure 188: This new compatible accessory building with a living unit above provides similar materials found on other historic accessory buildings.



Figure 189: This new compatible accessory building with an office space uses a similar character, form and parking location of historic accessory buildings.



Figure 190: This new accessory building with a living unit above may be too large for most contexts; however, it is a compatible scale for some historic contexts.

4.19 Design a new accessory building and/or carriage house to be compatible with, and subordinate to, the primary building and surrounding historic context.

- › Design the mass, form and roof shape of a new accessory building and/or carriage house to be compatible with the primary building and surrounding historic context.
- › Use materials that are of a similar color, texture and scale to materials of the primary building and in the surrounding historic context.
- › Use simplified versions of the primary building's features or other complementary details found in the surrounding historic context.
- › In most cases, the accessory building or carriage house should be subordinate in size to the primary building on the lot; however, there may be an exception to this approach. For example, if the existing primary building on the lot is very small, generally less than six hundred square feet, there may be an opportunity to build a larger accessory building or carriage house.

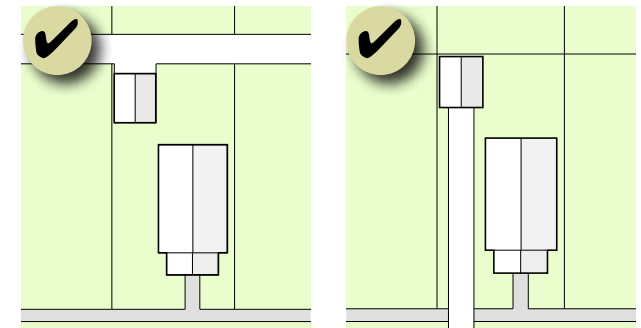

Figure 191: Alleyway access or a driveway along the side of the building to the accessory building in the rear (when an alley does not exist) is appropriate.

Energy Efficient Design

GREEN BUILDING AND THE CLIMATE ACTION PLAN

Existing Fort Collins building codes include many elements that support green building. The building code green amendments represent next steps along the path of integrating green building practices into mainstream construction.

The amendments apply to single-family detached housing, duplexes, townhomes and low-rise (one to three story) multifamily housing.

Energy efficiency standards are included in Chapter 3 which relate both to historic buildings and new construction. These standards address maintaining and improving resource and energy efficiency in a historic building, as well as methods for approaching energy conservation and generation technologies.

For in-depth descriptions of each individual practice in the package, visit Residential Package At-a-Glance:

http://www.fcgov.com/utilities/img/site_specific/uploads/Residential_APAAG_2011-03-29.pdf

For in-depth descriptions of each individual practice in the package, visit Building Code Green Amendments:

<http://www.fcgov.com/utilities/residential/green-building/amendments>

Also, when introducing sustainability improvements, it is important to maintain compatibility with the historic context.

- › Ensure that the sustainable design features of a new building are compatible with the historic context.
- › When using sustainable building materials, such as locally-sourced materials, recycled materials and materials with long life spans, ensure that they are compatible with typical materials seen in the surrounding historic context.
- › When designing a building to maximize passive solar potential (solar gain during the winter and deflection of summer sun), ensure that the building orientation remains compatible with typical orientation patterns in the surrounding historic context.
- › When orienting roofs to allow for the installation of solar collectors, ensure that roof forms and orientation remain compatible with typical orientation patterns in the surrounding historic context.

5

SITE WORK: DESIGN GUIDELINES FOR NEW CONSTRUCTION

Site Design: Guidelines for New Construction

This chapter provides site planning design guidelines for historic properties and new construction projects in the Old Town Neighborhoods. Site planning involves any work not directly related to a primary or accessory structure on a site. Important site considerations include building location, vehicular considerations, historic site features, landscape, urban gardens and service areas.

BUILDING LOCATION

It is important to place and orient new residential construction to be compatible with historic development patterns. This will retain the character of the neighborhoods.

5.1 Locate a new building to fit within the established setback (front and side) and yard patterns seen in the neighborhoods.

- › Locate a structure to maintain the side yard spacing pattern on the block as seen from the street.
- › Where front yard setbacks are uniform, place a new structure in alignment with its neighbors.
- › Where front yard setbacks for historic buildings vary, place a new structure within the established range of front yard setbacks on the block.

5.2 Preserve the traditional orientation of buildings along the street.

- › Orient a new building front to face the street.

5.3 Locate a new building to maximize passive solar potential.

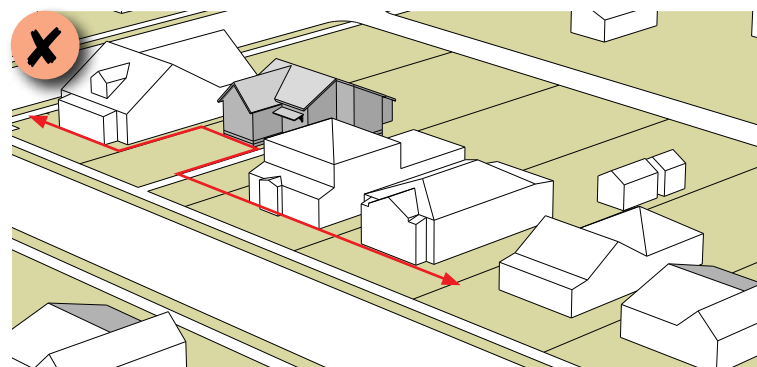
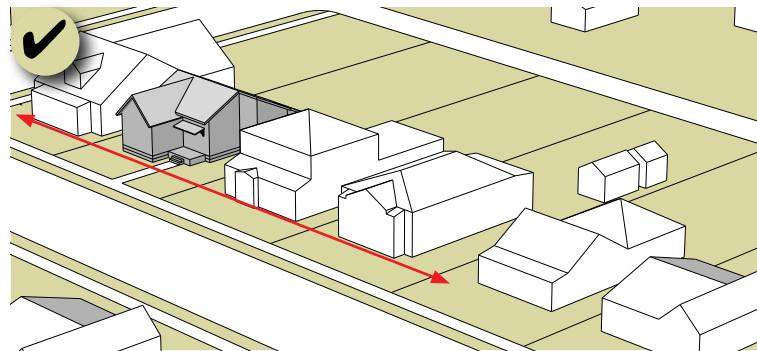

Figure 123: Locate a new building to fit within the established setback (front and side) and yard patterns seen in the neighborhoods. The sketch above shows appropriate placement, while the one below is placed inappropriately.

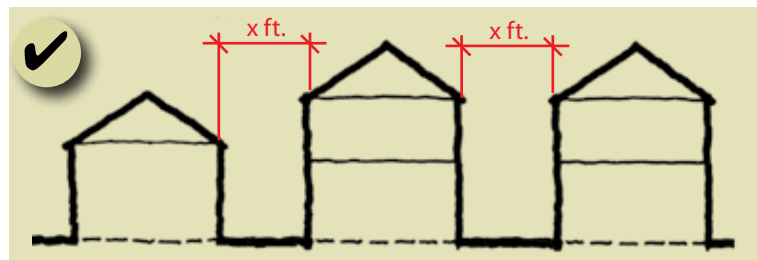

Figure 124: A variety of spacing occurs between buildings throughout the neighborhoods. Locate a structure to maintain the side yard spacing pattern on the block as seen from the street.



Figure 125: Preserve the traditional orientation of buildings along the street.



Figure 126: Where front yard setbacks are uniform, place a new structure in alignment with its neighbors.



Figure 127: Locate a new building to maximize passive solar potential. This example illustrates a building (top) imposing on its neighbor's solar access.

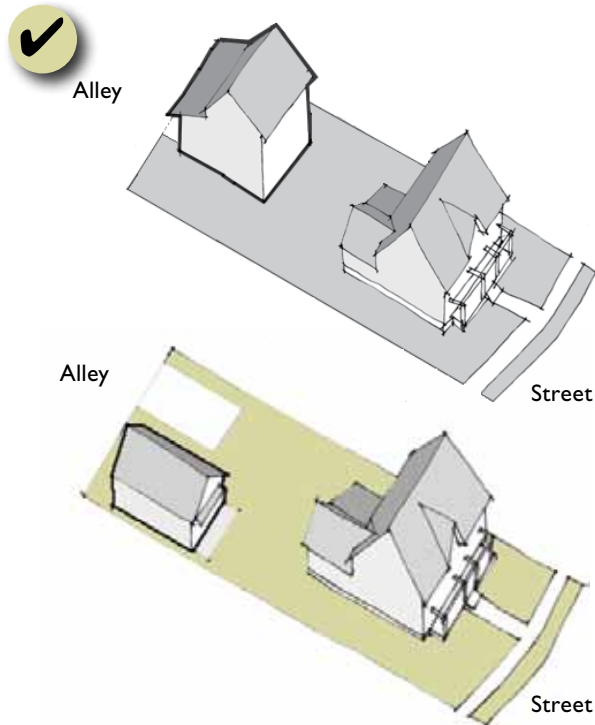

Figure 128: Parking areas should be located to the rear of the property, when physical conditions permit.



Figure 131: Provide auto access to a garage from an alley whenever feasible.



Figure 129: Minimizing the visual appearance of driveways and other paved surfaces is encouraged. When access from the alley isn't available, consider a small drive to the side of the house.

PARKING

In order to enhance the pedestrian-orientation of the neighborhoods, the visual impacts of cars should be minimized. On-site parking should be subordinate to other uses, and the front yard should not appear to be a “parking lot.”

5.4 Parking areas should not be visually obtrusive.

- › Parking areas should be located to the rear of the property, when physical conditions permit.
- › Parking should not be located in the front yard except in the driveway, if it exists.
- › The front of a garage should be set back a minimum of 10 feet from the primary front of a building, measured from behind the porch.



Figure 130: Traditionally, most parking was accessed from alleys in the neighborhoods; however, Character Area 6 reflects a development pattern where much of the parking access is off of the street leading to an attached garage.

VEHICULAR ACCESS

Traditionally, most parking was accessed from alleys in the neighborhoods. As a result, many blocks have very few curb cuts. This approach is preferred. In more recent subdivisions, however, access is sometimes provided from the street. In all cases, the visual impacts of driveways and curb cuts should be minimized.

5.5 Minimizing the visual impacts of curb cuts is encouraged.

- › If allowed through other city regulations, only one curb cut should be provided on a lot.
- › The width of a curb cut should be from 10 to 12 feet on a historic lot when accessed from the street.

5.6 Minimizing the visual appearance of driveways and other paved surfaces is encouraged.

- › Provide auto access from an alley.
- › Use a single lane driveway when physical conditions permit.
- › Locating a driveway to the side of the house is also acceptable.

LANDSCAPE AND SITE FEATURES

Site features and landscapes are an important part of the Old Town Neighborhoods. Proper treatment of these features helps retain the unique qualities that make the neighborhoods special and assists with the preservation and interpretation of historic buildings and character areas. It is important to ensure that new site features maintain and enhance the character of the neighborhood. It is also important to maintain a strong relationship between buildings and the street through sensitive site design.

5.7 Retain and restore historic site and landscape features.

- › Preserve original landscape and features, such as walkways, fences, site walls, street trees, historic stairways and special plantings or ornamental site features that are character-defining features of the property.
- › Retain original open space patterns at the sides and rear of a structure, whenever possible.
- › Sites should reflect the traditional topography on the block. Significant berms, fills and/or low entry swales in the front are inappropriate.

5.8 Preserve established trees

- › Preserve established and specimen trees in the front yard area.

5.9 Plan new site and landscape features to respect the character-defining features of the neighborhoods.

- › Landscape the street-facing portion of a lot to be consistent with historic landscape patterns on the street.
- › When introducing a new site feature, such as a stairway, fence or retaining wall, respect historical patterns in terms of placement, proportions and design compatibility with surrounding historic context.
- › When designing a new sidewalk or path, use colors, styles and finishes similar to those seen in nearby historic sidewalks.
- › Avoid introducing new site features that convey a false sense of history, such as faux historic street lights.

5.10 Maintain front yard landscape areas.

- › Reserve most of the front yard as open lawn, and/or designed xeriscape that uses low-water plantings. Urban gardens are also appropriate when they maintain the appearance of a traditional landscaped front yard.



Figure 132: Preserve original landscape and features.



Figure 133: Reserve most of the front yard as open lawn, and/or designed xeriscape that uses low-water plantings.

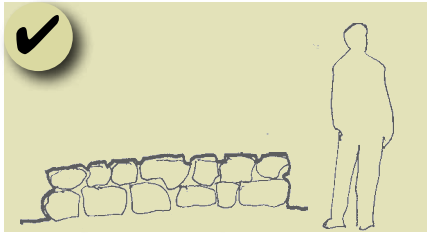

Rock

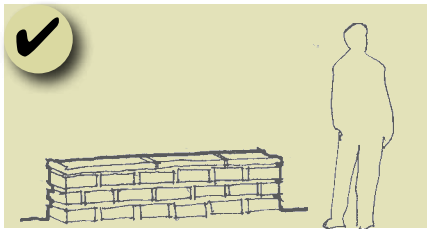

Brick

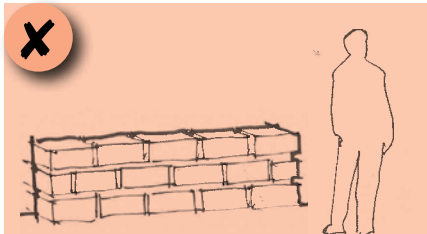

Concrete Masonry Unit (CMU)



Ashlar stone is appropriate; however, this wall is too high for most contexts

Figure 135: Use materials that are common to the historic context or that relate to the historic property.



Figure 134: Use materials that are common to the historic context or that relate to the historic property.



5.11 Design a new front yard fence to minimize impacts on the historic context.

- › Design a new front yard fence to be simple, open and low.
- › Use historic fence and wall materials present in the surrounding historic context. Do not use vinyl, chain link or other nontraditional fence materials.
- › Do not install opaque fencing along the street. A fence should typically be at least 50% open.

5.12 Design a new rear yard fence that is compatible with the surrounding area.

- › Locate a rear yard fence to have minimal visibility from public view.
- › Situate a rear or side yard fence back from the front façade.
- › Use a rear yard fence type and materials traditionally found in the historic context, such as simple iron, wood, or open picket fence. When installing a wooden fence, ensure that the pickets face to the exterior, and the framing faces to the inside.

- › Locate a rear yard fence along traditional lot lines; however, smaller fenced in areas are also appropriate for dogs runs, gardens, chicken coops, etc.

5.13 Locate and design a new retaining wall to minimize impacts on the historic context.

- › Use a low wall to help stabilize the yard while maintaining most of the historic slope.
- › Design a new retaining wall to minimize visual impacts on the character-defining features of the historic property and context.
- › Use materials that are common to the historic context or that relate to the historic property. For example, if a stone wall is a part of the design tradition, the wall should be stone, or stone-faced. CMU and railroad ties are inappropriate in the front yard.
- › Avoid using terraced retaining walls.
- › Do not completely replace the slope with a tall retaining wall.

URBAN GARDENS

Urban gardens are encouraged on traditional family lots to promote sustainability. However, the landscape plan should consider the traditional context of the neighborhoods. Front yards are typically planted with larger/higher plant materials located closer to the house, and often end in low scale plant materials such as grass and/or ground cover at the sidewalk edge.

5.14 Locate and design urban gardens to complement traditional planting patterns.

- › Traditional front yard planting patterns are encouraged.
- › Large plant boxes should be located in the rear of the yard.
- › Frame front yard vegetable gardens with flowering plants or low shrubs to buffer the maturing plants over the season.
- › Consider a permaculture environment when planning a garden.



Figure 136: Locate and design urban gardens to complement traditional planting patterns. This photograph showcases a compatible urban garden design that is located in the rear of a property and preserves traditional sideyard setbacks.

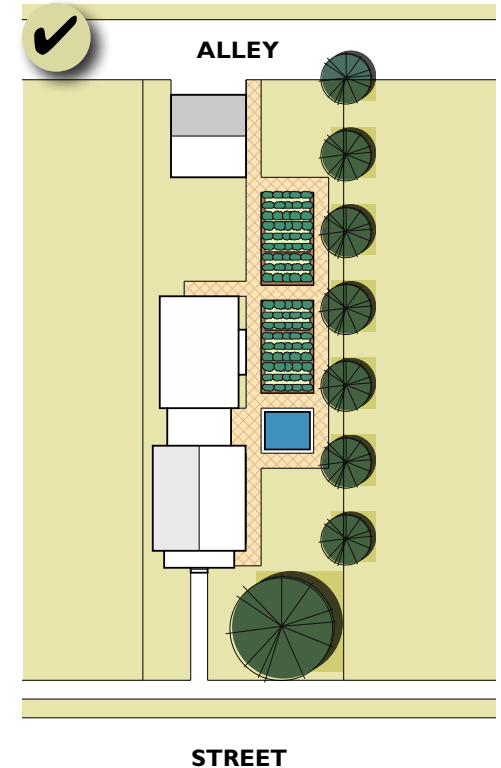

Figure 137: This plan illustrates the context of the image to the left. Note the traditional front yard lawn and the rear side yard urban garden.

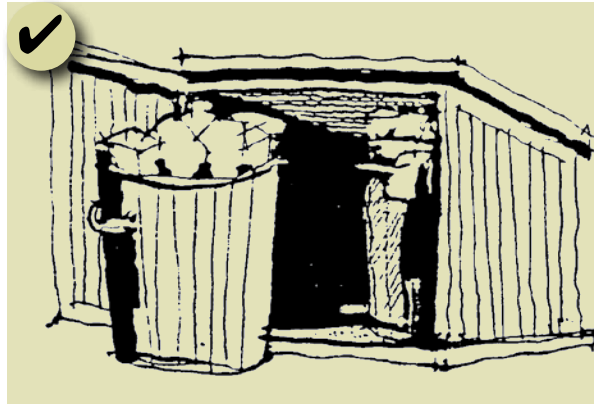

Figure 138: Service areas should be screened from the street with fences, walls and plantings, or a combination of these elements.

SERVICE AREAS

Service areas include locations for trash containers, transformers, electrical equipment and other mechanical equipment that may require an exterior facility. In all cases, these features should remain visually unobtrusive from the street.

5.15 Minimizing the unpleasant visual appearance of service areas is encouraged.

- › Locating dumpsters and other service equipment to the rear of the lot, when physical conditions permit, is encouraged.
- › Service areas should be screened from the street with fences, walls and plantings, or a combination of these elements.



A

APPENDIX

Character Area Summary Charts

Distribution of Properties Within Character Areas

This line in the chart indicates that Character Areas 2 and 4 contain relatively high numbers of properties out of the total for Old Town, that Character Areas 1 and 6 each have a moderate amount and that Character Areas 3 and 5 have fewer than the others. This may be useful to consider when evaluating the potential impact a project will have on its surroundings.

Lot Size

This table presents lot sizes in 1,000 square foot increments for each Character Area. It illustrates that some areas tend to have a concentration of lots in the higher size categories, while others have concentrations in the smaller sizes. Still others have a focus on middle lot sizes. This should be considered when anticipating the impact that building mass and scale for a new project may have. It also may indicate areas where a wider diversity of house size correlates with a wider range of lot size.

CHARACTER AREA SUMMARY

	Character Area 1	Character Area 2	Character Area 3	Character Area 4	Character Area 5	Character Area 6
Distribution of Properties Within Character Areas						
Total Properties	11%	24%	4%	36%	5%	19%
Lot Size						
Typical Range	Varies	Varies	4,000 - 5,999 sf	Varies	4,000 - 6,999 sf	6,000 - 6,999 sf
4,000 sf or less	7%	6%	5%	6%	4%	1%
4,000-4,999 sf	9%	10%	26%	7%	12%	1%
5,000-5,999 sf	8%	20%	12%	12%	24%	8%
6,000-6,999 sf	15%	13%	5%	12%	17%	43%
7,000-7,999 sf	12%	14%	3%	13%	10%	14%
8,000-8,999 sf	10%	6%	0%	15%	11%	10%
9,000-9,999 sf	28%	25%	2%	17%	12%	6%
10,000 sf or more	11%	5%	1%	16%	10%	11%
Average	8,020 sf	7,285 sf	6,540 sf	8,590 sf	7,085 sf	7,385 sf

CHARACTER AREA SUMMARY

	Character Area 1	Character Area 2	Character Area 3	Character Area 4	Character Area 5	Character Area 6
Lot Width						
Typical Range	26-75'	26-75'	26-50'	26-75'	26-75'	51-75'
25' or less	2%	15	3%	3%	2%	1%
26'-50'	52%	61%	75%	45%	36%	13%
51'-75'	33%	28%	17%	35%	45%	68%
76-100'	3%	6%	1%	11%	11%	14%
101' +	7%	3%	5%	6%	6%	4%
Average	57 feet	53 feet	48 feet	60 feet	60 feet	65 feet
Lot Coverage						
Typical Range	11-40%	11-40%	11-30%	11-30%	11-30%	21-30%
0-10%	1%	3%	3%	7%	7%	2%
11-20%	23%	22%	28%	31%	28%	22%
21-30%	45%	45%	53%	41%	49%	58%
31-40%	21%	23%	12%	17%	15%	16%
40% +	10%	7%	4%	5%	4%	2%
Average	27%	27%	24%	24%	25%	25%

Lot Width

The portion of the size of a house front to the width of the lot impacts the perception of building mass. The concentration of similarly sized lot widths is a key indicator in each of the Character Areas that differentiates one from another.

Lot Coverage

The percentage of the lot that is covered with building footprints is an indicator of the relative perception of intensity of development. Character Area 6, for example, has a relatively low lot coverage, with more than half of its properties in the middle range.

Year Built

A range of typical building years is shown for each Character Area. Some have relatively narrow time spans, such as Character Area 1 for example. This suggests that a higher degree of consistency in building scale and character may be found there.

Year Remodeled

The percentage of properties that have been remodeled may help predict the degree of consistency or diversity that exists in each Character Area. Those with a higher percentage of remodeled buildings are likely to exhibit more variety in character.

Building Size

Typical building size varies substantially across the different Character Areas. Character Area 3, for example, has some of the smallest houses (and smallest lots). This could be a factor in considering the appropriate scale for new infill construction.

CHARACTER AREA SUMMARY						
	Character Area 1	Character Area 2	Character Area 3	Character Area 4	Character Area 5	Character Area 6
Year Built						
Typical Range	1882-1920	1901-1920	1881-1920	1901-1960	1941-1960	1941-1960
Average	1912	1916	1914	1934	1951	1956
Year Remodeled						
Typical Range	2000-2009	2000-2009	1980-2009	2000-2009	1990-2009	1970-2009
Percent Remodeled	51%	39%	45%	34%	30%	24%
Building Size						
Typical Range	500 - 2,499 sf	500 - 1,499 sf	500 - 999 sf	500 - 1,499 sf	500 - 1,499 sf	1,000 - 1,499 sf
999 sf or less	14%	37%	69%	40%	43%	26%
1,000 - 1,499 sf	35%	40%	27%	34%	40%	56%
1,500 - 1,999 sf	23%	16%	3%	13%	14%	14%
2,000 - 2,499 sf	18%	5%	1%	9%	2%	3%
2,500 sf or greater	10%	1%	-	3%	3%	4%

CHARACTER AREA SUMMARY

	Character Area 1	Character Area 2	Character Area 3	Character Area 4	Character Area 5	Character Area 6
Average	1,670 sf	1,220 sf	895 sf	1,280 sf	1,148 sf	1,225 sf
Building Height						
Typical Range	1-2 stories	1-1.5 stories	1 story	1-2 stories	1 story	1 story
1 story	48%	79%	93%	78%	90%	91%
1.5 story	25%	13%	4%	10%	5%	1%
2 story	25%	9%	2%	12%	5%	8%
2.5 story	1%	-	-	0%	-	-
Floor Area Ratio (FAR)						
Typical Range	0.4 or less	0.3 or less	0.11-0.2	0.3 or less	0.3 or less	0.11-0.2
0.0-0.11	8%	12%	13%	11%	11%	8%
0.11-0.2	42%	56%	72%	54%	63%	78%
0.21-0.3	32%	24%	11%	20%	24%	13%
0.31-0.4	14%	6%	5%	5%	1%	1%
0.4 +	5%	2%	-	1%	1%	-
Average	0.22	0.19	0.16	0.17	0.17	0.16

Building Height

Those areas with buildings that are predominantly one story appear in this chart. Character Areas 3, 5 and 6 are noteworthy in this respect. Maintaining this sense of scale will be important. Other Character Areas have buildings that include a mix of one and two story homes. Some areas exhibit a high degree of similarity in height, while others are more diverse. This may be a factor in considering the compatibility of new construction.

Floor Area Ratio

The percentage of building square footage to lot size is a ratio that can suggest relative intensity of development. Some of the Character Areas have notably low ratios and with a high degree of consistency (Character Area 6 for example). Others have a wider range of FAR (such as Character Area 1).

Resource List

Provided below is a list of weblinks that occur throughout the document and more. Please use these resources to further understand the concepts and intent of the design guidelines.

CITY OF FORT COLLINS RESOURCES:

Historic Preservation Programs and Processes: <http://www.fcgov.com/historicpreservation/>

Design Assistance Program: <http://www.fcgov.com/historicpreservation/design-assistance.php>

Landmark Rehabilitation Loans: <http://www.fcgov.com/historicpreservation/landmark-rehabilitation.php>

Land Use Code: https://www.municode.com/library/colfort_collins/codes/land_use

NATIONAL PARK SERVICE PRESERVATION BRIEF SERIES:

Preservation Brief 1: Assessing Cleaning and Water-Repellent Treatments for Historic Masonry Buildings: <http://www.nps.gov/tps/how-to-preserve/briefs/1-cleaning-water-repellent.htm>

Preservation Brief 2: Repointing Mortar Joints in Historic Masonry Buildings: <http://www.nps.gov/tps/how-to-preserve/briefs/2-repoint-mortar-joints.htm>

Preservation Brief 3: Improving Energy Efficiency in Historic Buildings: <http://www.nps.gov/tps/how-to-preserve/briefs/3-improve-energy-efficiency.htm>

Preservation Brief 4: Roofing for Historic Buildings: <https://www.nps.gov/TPS/how-to-preserve/briefs/4-roofing.htm>

Preservation Brief 6: Dangers of Abrasive Cleaning to Historic Buildings: <https://www.nps.gov/TPS/how-to-preserve/briefs/6-dangers-abrasive-cleaning.htm>

Preservation Brief 8: Aluminum and Vinyl Siding on Historic Buildings: <https://www.nps.gov/TPS/how-to-preserve/briefs/8-aluminum-vinyl-siding.htm>

Preservation Brief 9: The Repair of Historic Wooden Windows: <http://www.nps.gov/tps/how-to-preserve/briefs/9-wooden-windows.htm>

Preservation Brief 10: Exterior Paint Problems on Historic Woodwork: <http://www.nps.gov/tps/how-to-preserve/briefs/10-paint-problems.htm>

Preservation Brief 13: The Repair and Thermal Upgrading of Historic Steel Windows: <http://www.nps.gov/tps/how-to-preserve/briefs/13-steel-windows.htm>

Preservation Brief 14: New Exterior Additions to Historic Buildings: Preservation Concerns: <https://www.nps.gov/TPS/how-to-preserve/briefs/14-exterior-additions.htm>

Preservation Brief 16: The Use of Substitute Materials on Historic Building Exteriors: <http://www.nps.gov/tps/how-to-preserve/briefs/16-substitute-materials.htm>

Preservation Brief 17: Architectural Character - Identifying the Visual Aspects of Historic Buildings as an Aid to Preserving Character: <http://www.nps.gov/tps/how-to-preserve/briefs/17-architectural-character.htm>

Preservation Brief 19: The Repair and Replacement of Historic Wooden Shingle Roofs: <https://www.nps.gov/TPS/how-to-preserve/briefs/19-wooden-shingle-roofs.htm>

Preservation Brief 22: The Preservation and Repair of Historic Stucco: <https://www.nps.gov/TPS/how-to-preserve/briefs/22-stucco.htm>

Preservation Brief 36: Protecting Cultural Landscapes: Planning, Treatment and Management of Historic Landscapes: <https://www.nps.gov/TPS/how-to-preserve/briefs/36-cultural-landscapes.htm>

NATIONAL TRUST OF HISTORIC PRESERVATION RESOURCES:

Window Retrofit Article from the National Trust for Historic Preservation web site: <http://www.preservationnation.org/who-we-are/press-center/press-releases/2012/new-windows-study.html>

Window Treatments, National Park Service Tech Notes: <http://www.nps.gov/tps/how-to-preserve/tech-notes.htm>

Glossary

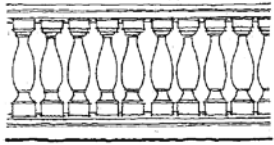

Baluster

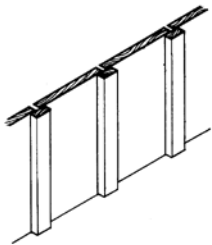

Board and batten

Addition: New construction added to an existing building or structure.

Alteration: Any act or process that changes one or more of the exterior architectural features of a structure, including, but not limited to, the erection, construction, reconstruction, addition, sand blasting, water blasting, chemical cleaning, chemical stopping, or removal of any structure, but not including changes to the color of exterior paint.

Alignment: The arrangement of objects along a straight line.

Appropriate: Especially suitable or compatible.

Asphalt shingles: A type of roofing material composed of layers of saturated felt, cloth or paper, and coated with a tar, or asphalt substance, and granules.

Attic: The upper level of a building, not of full ceiling height, directly beneath the roof.

Baluster: Vertical member, usually of wood, which supports the railing of a porch or the handrail of a stairway.

Balustrade: A railing or parapet consisting of a handrail on balusters, sometimes also includes a bottom rail.

Bargeboard: A board, often decoratively carved, which hangs from the projecting edge of a roof gable.

Bay window: A projecting window that forms an extension to the floor space of the internal rooms; usually extends to the ground level.

Board and batten: Vertical plank siding with



Bracket



Clapboards

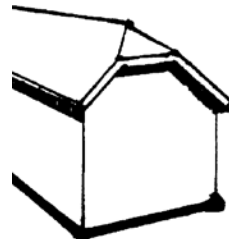

Clipped Gable

joints covered by narrow wood strip

Bracket: A supporting member for a projecting element or shelf, sometimes in the shape of an inverted L and sometimes as a solid piece or a triangular truss.

Bulkhead: In commercial buildings, the area below the display windows at the sidewalk level.

Bungalow: Common house form of the early 20th century distinguished by horizontal emphasis, wide eaves, large porches and multi-light doors and window

Capital: The head of a column or pilaster.

Casement window: A window with one or two sashes which are hinged at the sides and usually open outward.

Clapboard: Large wood boards which taper slightly so they overlap; applied horizontally on buildings of frame construction.

Clipped gable: A gable roof where the ends of the ridge are terminated in a small, diagonal roof surface.

Column: A supporting post found on storefronts, porches and balconies; may be fluted or smooth.

Compatible: In harmony with location and surroundings.

Contemporary: Reflecting characteristics of the current period. Contemporary denotes characteristics which illustrate that a building, structure, or detail was constructed in the present or recent past rather than being imitative or reflective of a historic design.

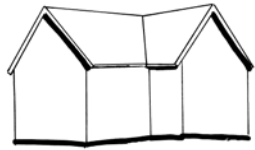

Cross-gable

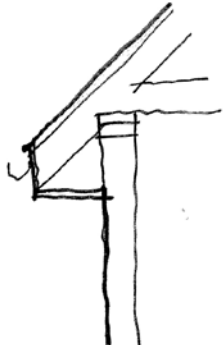

Eave

Context: The setting in which a historic element, site, structure, street, or district exists.

Corbel: A bracket form produced by courses of wood or masonry which extend in successive stages from the wall surface.

Corinthian order: Most ornate classical order characterized by a capital with ornamental acanthus leaves and curled fern shoots.

Cornerboard: A board used to cover the exposed ends of wood siding to give a finished appearance and make the building watertight.

Cornice: The projecting uppermost portion of a wall, often treated in a decorative manner with brackets.

Cross-gable: A secondary gable roof which meets the primary roof at right angles.

Dentil: One of a row of small blocks used as part of the decoration in a frieze or cornice.

Doorframe: The part of a door opening to which a door is hinged. A doorframe consists of two vertical members called *jamb*s and a horizontal top member called a *lintel* or *head*.

Doric order: A classical order with simple, unadorned capitals, and with no base.

Dormer: A structural extension of a building's roof, intended to provide light and headroom in an attic space; usually contains window(s) on its vertical face.

Double-hung window: A window with two balanced sashes, with one sliding over the other vertically to open.



Finial

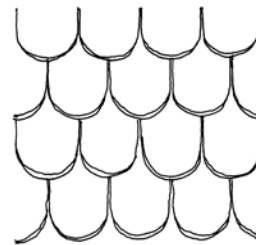

Fishscale shingles

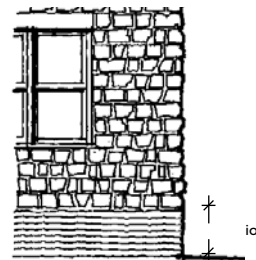

Foundation



Gable roof

Eave: The lower portion of the sloping surface of a roof, especially the part that overhangs the building's wall.

Ell: The rear wing of a house, generally one room wide and running perpendicular to the principal building.

Engaged column: A round column attached to a wall.

Facade: The "face" of the building; usually refers to the main side of the building, though it can be applied to all sides.

Fanlight: A semi-elliptical design used both over doors and in gables either as a window or as a board.

Fascia: A flat horizontal wooden member used as a facing at the ends of roof rafters and in the cornice area.

Fenestration: The arrangement of windows and other exterior openings on a building.

Finial: A projecting decorative element, usually of metal, at the top of a roof turret or gable.

Fishscale shingles: A decorative pattern of wall shingles composed of staggered horizontal rows of wooden shingles with half-round ends.

Form: The overall shape of a structure (i.e., most structures are rectangular in form).

Foundation: The lowest exposed portion of the building wall, which supports the structure above.

Gable roof: A pitched roof with one downward slope on either side of a central, horizontal ridge.

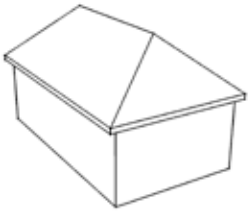

Hipped roof

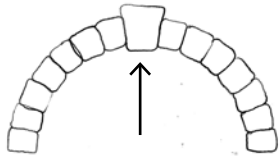

Keystone

Head: The top horizontal member over a door or window opening.

Hipped roof: Roof with uniform slopes on all sides.

Historic imitation: New construction or rehabilitation where elements or components mimic an architectural style but are not of the same historic period as the existing buildings (historic replica).

Hood mold: Decorative, projecting element placed over a window; may extend down the sides of a window as well as surround the top.

In-Kind replacement: To replace a feature of a building with materials of the same characteristics, such as material, texture, color, etc.

Integrity: A property retains its integrity, if a sufficient percentage of the structure retains its historic fabric. The majority of a building's original structural system, materials, and character defining features also should remain intact. These may include architectural details, such as dormers, porches, ornamental brackets, moldings and materials, as well as the overall mass and form of the building.

Ionic order: One of the five classical orders used to describe decorative scroll capitals.

Infill: New construction where there had been an opening before, such as a new building between two older structures.

Keystone: The wedge-shaped top or center member of an arch.

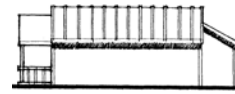

Metal standing seam roof.



Lap siding

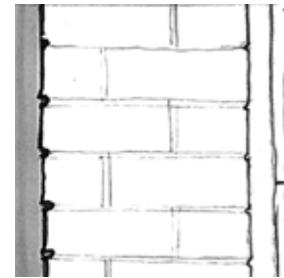

Masonry

Landmark: A property, structure or natural object designated as a "landmark" by ordinance of the city council, pursuant to procedures prescribed in this title, that is worthy of rehabilitation, restoration and presentation because of its historic or architectural significance to the city.

Lap siding: See clapboards.

Lattice: Criss-cross pattern of thin wooden slats most often found covering the open space beneath a porch.

Lintel: Horizontal structural element at the top of a window or door; in masonry walls, may be of wood, stone or metal.

Maintain: To keep in an existing state of preservation or repair.

Mansard roof: A roof with a double slope on all four sides, with the lower slope being almost vertical and the upper almost horizontal.

Masonry: Construction materials such as stone, brick, concrete block or tile.

Metal standing seam roof: A roof composed of overlapping sections of metal such as copper-bearing steel or iron coated with a terne alloy of lead and tin. These roofs were attached or crimped together in various raised seams for which the roof are named.

Modillion: A horizontal bracket or scroll which appears at the building or porch cornice. Known as a block modillion if a flat block.

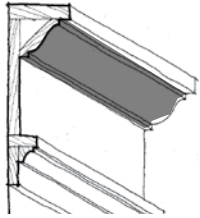

Molding

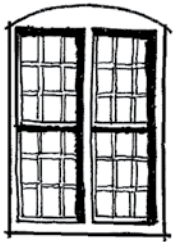

Muntin

Molding: A decorative band or strip of material with a constant profile or section designed to cast interesting shadows. It is generally used in cornices and as trim around window and door openings.

Mortar: A mixture of sand, lime, cement, and water used as a binding agent in masonry construction.

Mullion: A wooden vertical piece that divides window sash, doors or panels set close together in a series.

Multi-light window: A window sash composed of more than one pane of glass.

Muntin: The wooden pieces that make up the small subdivisions in a multiple-pane glass window.

New construction: Construction which is characterized by the introduction of new elements, sites, buildings, or structures or additions to existing buildings and structures in historic areas and districts.

Obscured: Covered, concealed or hidden from view.

Opaque fence: A fence that one *cannot* see through.

Orientation: Generally, orientation refers to the manner in which a building relates to the street. The entrance to the building plays a large role in the building's orientation, and in most cases it should face the street.

Ornamentation: Decoration, usually non-structural and not essential from a practical standpoint, which is applied to a building to increase its distinctiveness and visual interest.



Pediment



Portico

Palladian Window: A three-part window, with a round-arched central window flanked by two rectangular windows whose height reaches the point where the arch begins on the central window.

Panel: A sunken or raised portion of a door with a frame-like border.

Parapet: The portion of an exterior wall which rises entirely above the roof, usually in the form of a low retaining wall; the parapet may be shaped or stepped.

Pediment: The triangular face of a roof gable; or a gable which is used in porches, or as decoration over windows, doors and dormers.

Piazza: Early Americans described a piazza as the open space alongside a house sheltered by a roof and supported by pillars. The term is used interchangeably with veranda and can be directly applied to Charleston architecture.

Pitch: The degree of the slope of a roof.

Portico: An entrance porch, usually supported by columns and sheltering only the entry.

Preservation: The act or process of applying measures to sustain the existing form, integrity and materials of a building or structure, and the existing form and vegetative cover of a site. It may include initial stabilization work, where necessary, as well as ongoing maintenance of the historic building materials.

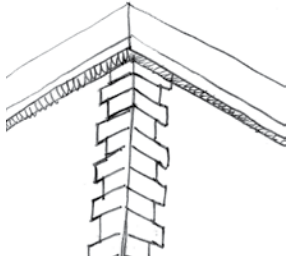

Quoins

Prism Glass: Small panes of glass, usually set in a wooden or metal framework in the transom over a storefront or entrance; the glass is molded in a special pattern such that small prisms project daylight into the interior of the building.

Quoins: A series of stone, bricks, or wood panels ornamenting the outside of a wall.

Reconstruction: The act or process of reproducing by new construction the exact form and detail of a vanished building, structure or object, or part thereof, as it appeared at a specific period of time.

Rehabilitation: The act or process of returning a property to a state of utility through repair or alteration which makes possible an efficient contemporary use while preserving those portions or features of the property which are significant to its historical, architectural and cultural value.

Restoration: The act or process of accurately recovering the form and details of a property and its setting as it appeared at a particular period of time by means of the removal of later work or by the replacement of missing earlier work.

Retain: To keep secure and intact. In the guidelines, “retain” and “maintain” describe the act of keeping an element, detail, or structure and continuing the same level of repair to aid in the preservation of elements, sites and structures.

Ridge: The top horizontal member of a roof where the sloping surfaces meet.

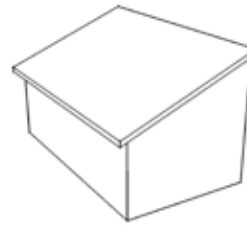

Shed roof



Sidelight

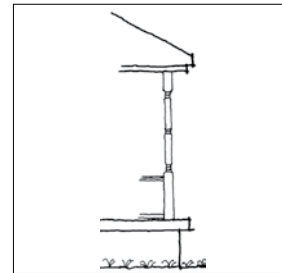

Spindles

Roof Rafter: Long wooden structural members which run from ridge to eaves and which provide structural support for the roof sheathing and roofing materials.

Sash: The moveable framework containing the glass in a window.

Scale: Proportional elements that demonstrate the size, materials, and style of buildings.

Segmental Arch: A type of circular arch which does not extend on the sides to a full half circle; often found at the tops of windows.

Sheathing: A sub-surface material, usually wood, which covers exterior walls or roofs before application of siding or roofing materials.

Shed roof: A gently-pitched, almost flat roof with only one slope.

Shingles: Wood which is split into flat shingles and different shapes. Wood shingles are common elements to the Queen Anne and Bungalow styles.

Sidelight: A glass panel, usually of multiple panes, to either side of a door; often used in conjunction with a transom.

Siding: The exterior wall covering or sheathing of a structure.

Sill: The lowest horizontal member in a frame or opening for a window or door. Also, the lowest horizontal member in a framed wall or partition.

Soffit: A flat wooden member used as a finished undersurface for any overhead exposed part of a building, such as a cornice.

Spindles: Slender, elaborately turned wood dowels or rods often used in screens and porch trim.

Transom: A glass panel, sometimes fixed and sometimes movable, which is placed over a door or window to provide additional natural light to the interior of the building. Used on both residential and commercial buildings.

Trim: The decorative framing of openings and other features on a facade.

Turret: Projecting corner bay or tower, usually round, often with a conical roof.

Vapor Barrier: A waterproof material which is used to prevent moisture from migrating from damp to dry areas where it may condense and cause problems.

Veranda: A broad sweeping porch, typically running the length of the facade.

Vergeboard: The vertical face board following and set under the roof edge of a gable, sometimes decorated by carving.

Vernacular: Architecture which draws more on folk traditions and plain straightforward building techniques rather than on the rules, principles and ornamentation of architectural styles.

Visual Continuity: A sense of unity or belonging together that elements of the built environment exhibit because of similarities among them.

